

CAD/DATA  
70-140H-8/TH8  Bore A. C is available.

### LB for 7MPa

70H-8  1 LB Bore  B  B Stroke -  A  B

Drill hole for rod dia. of  $\phi 100$  or more

Rod dia.	OF	DF
$\phi 100$	$\phi 99.5$	$\phi 12$
$\phi 112$	$\phi 111.5$	$\phi 15$
$\phi 125$	$\phi 124.5$	$\phi 15$
$\phi 140$	$\phi 139.5$	$\phi 15$

LB accessory working face ( $\phi 32$  to  $\phi 80$ )

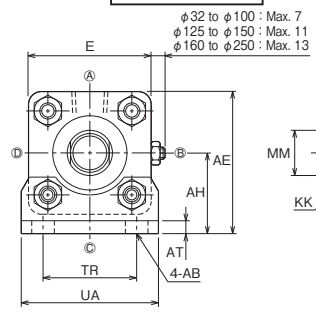

$\phi 32$  to  $\phi 100$ : Max. 7  
 $\phi 125$  to  $\phi 150$ : Max. 11  
 $\phi 160$  to  $\phi 250$ : Max. 13

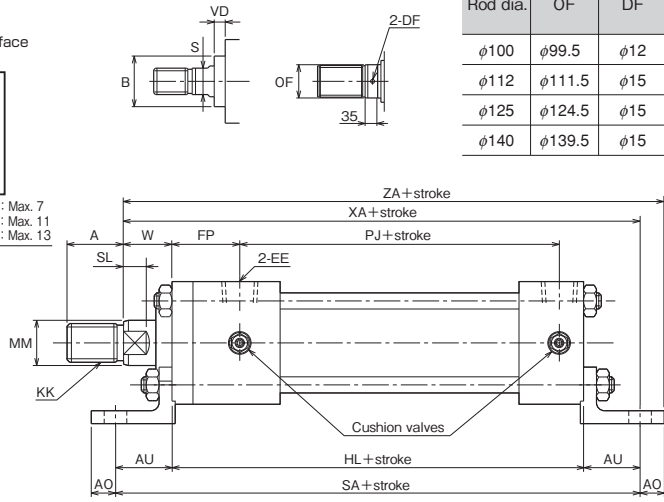

- For dimensions not shown in these figures, refer to the SD style (basic style).
- For the mounting of sensors, refer to the dimensional drawings of "Switch Set." All the contents other than "Sensor mounting dimensions" are the same.
- If the port size exceeds 1 inch, it is recommended to order G thread or pipe flange. In such a case, contact us. (Order made)

### Double rod type ( $\phi 32$ to $\phi 250$ /rod B or C) for loading on both sides

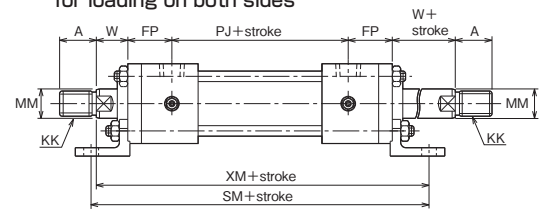

• The Switch Set ( $\phi 32$  to  $\phi 140$ ) is also within the standard stroke range.

### With Boots

70-140H-8/TH8  Bore K

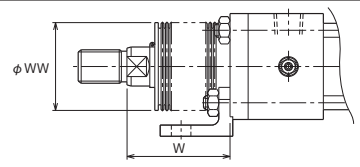

	Standard	Semi-standard	
Material	Nylon tarpaulin	Chloroprene	Conex
Heat proof	80°C	130°C	200°C

Notes)

- Remember that the heat proof field in the table above shows the allowable temperatures for the boots, not for the cylinder.
- Conex is the registered trademark of Teijin Limited.
- The boots have been mounted at our factory prior to delivery.
- The boots are not available for the rod A in LB mounting.

Dimension W Rod B/C	$\phi 32$	$\phi 40$	$\phi 50$	$\phi 63$	$\phi 80$	$\phi 100$	$\phi 125$	$\phi 140$	$\phi 150$	$\phi 160$	$\phi 180$	$\phi 200$	$\phi 224$	$\phi 250$
Nylon tarpaulin	1/3	1/3.5	1/4	1/4	1/4	1/4	1/4	1/4	1/4	1/4	1/4	1/4	1/4	1/4
Chloroprene	stroke+X	stroke+X	stroke+X	stroke+X	stroke+X	stroke+X	stroke+X	stroke+X	stroke+X	stroke+X	stroke+X	stroke+X	stroke+X	stroke+X
Conex	1/2	1/2.5	1/3	1/3	1/3	1/3	1/3	1/3	1/3	1/3	1/3	1/3	1/3	1/3
	stroke+X	stroke+X	stroke+X	stroke+X	stroke+X	stroke+X	stroke+X	stroke+X	stroke+X	stroke+X	stroke+X	stroke+X	stroke+X	stroke+X

• If the calculated value has a fractional part, round it up.

### Dimensional Table

Symbol Bore	Rod B							Rod C							Rod A							
	A	B	KK	MM	S	SL	VD	A	B	KK	MM	S	SL	VD	A	B	KK	MM	S	SL	VD	
$\phi 32$	25	$\phi 34$	M16×1.5	$\phi 18$	14	10	10	—	—	—	—	—	—	—	—	—	—	—	—	—	—	—
$\phi 40$	30	$\phi 40$	M20×1.5	$\phi 22.4$	19	11	10	25	$\phi 36$	M16×1.5	$\phi 18$	14	10	10	35	$\phi 43$	M24×1.5	$\phi 28$	24	14	17	—
$\phi 50$	35	$\phi 46$	M24×1.5	$\phi 28$	24	14	10	30	$\phi 40$	M20×1.5	$\phi 22.4$	19	11	10	45	$\phi 50$	M30×1.5	$\phi 35.5$	30	16	17	—
$\phi 63$	45	$\phi 55$	M30×1.5	$\phi 35.5$	30	16	10	35	$\phi 46$	M24×1.5	$\phi 28$	24	14	10	60	$\phi 65$	M39×1.5	$\phi 45$	41	20	19	—
$\phi 80$	60	$\phi 65$	M39×1.5	$\phi 45$	41	20	10	45	$\phi 55$	M30×1.5	$\phi 35.5$	30	16	9	75	$\phi 80$	M48×1.5	$\phi 56$	50	23	20	—
$\phi 100$	75	$\phi 80$	M48×1.5	$\phi 56$	50	23	10	60	$\phi 65$	M39×1.5	$\phi 45$	41	20	10	95	$\phi 95$	M64×2	$\phi 71$	65	27	23	—
$\phi 125$	95	$\phi 95$	M64×2	$\phi 71$	65	27	10	75	$\phi 80$	M48×1.5	$\phi 56$	50	23	10	120	$\phi 115$	M80×2	$\phi 90$	85	33	17	—
$\phi 140$	110	$\phi 105$	M72×2	$\phi 80$	75	31	10	80	$\phi 85$	M56×2	$\phi 63$	55	24	10	—	—	—	—	—	—	—	—
$\phi 150$	115	$\phi 110$	M76×2	$\phi 85$	80	33	10	85	$\phi 90$	M60×2	$\phi 67$	60	30	10	—	—	—	—	—	—	—	—
$\phi 160$	120	$\phi 115$	M80×2	$\phi 90$	85	33	10	95	$\phi 95$	M64×2	$\phi 71$	65	27	10	—	—	—	—	—	—	—	—
$\phi 180$	140	$\phi 125$	M95×2	$\phi 100$	—	—	10	110	$\phi 105$	M72×2	$\phi 80$	75	31	10	—	—	—	—	—	—	—	—
$\phi 200$	150	$\phi 140$	M100×2	$\phi 112$	—	—	10	120	$\phi 115$	M80×2	$\phi 90$	85	33	10	—	—	—	—	—	—	—	—
$\phi 224$	180	$\phi 150$	M120×2	$\phi 125$	—	—	10	140	$\phi 125$	M95×2	$\phi 100$	—	—	10	—	—	—	—	—	—	—	—
$\phi 250$	195	$\phi 170$	M130×2	$\phi 140$	—	—	10	150	$\phi 140$	M100×2	$\phi 112$	—	—	10	—	—	—	—	—	—	—	—

Symbol Bore	AB	AE	AH	AO	AT	AU	E	EE	FP	HL	PJ	SA	SM	TR	UA	W		XA		ZA		
																B·C	A	B·C	A	B·C	A	
$\phi 32$	$\phi 11$	69	40±0.15	13	8	32	58	Rc3/8	38	141	90	205	230	40	62	30	—	203	—	228	216	—
$\phi 40$	$\phi 11$	75.5	43±0.15	13	8	32	65	Rc3/8	38	141	90	205	230	46	69	30	35	203	208	228	216	221
$\phi 50$	$\phi 14$	88	50±0.15	15	8	35	76	Rc1/2	42	155	98	225	252	58	85	30	41	220	231	247	235	246
$\phi 63$	$\phi 18$	105	60±0.15	18	10	42	90	Rc1/2	46	163	102	247	278	65	98	35	48	240	253	271	258	271
$\phi 80$	$\phi 18$	127	72±0.25	20	12	50	110	Rc3/4	56	184	110	284	322	87	118	35	51	269	285	307	289	305
$\phi 100$	$\phi 22$	152.5	85±0.25	23	12	55	135	Rc3/4	58	192	116	302	342	109	150	40	57	287	304	327	310	327
$\phi 125$	$\phi 26$	187.5	105±0.25	29	15	66	165	Rc1	67	220	130	352	396	130	175	45	57	331	343	375	360	372
$\phi 140$	$\phi 26$	207.5	115±0.25	30	18	70	185	Rc1	69	230	138	370	416	145	195	50	—	350	—	396	380	—
$\phi 150$	$\phi 30$	221	123±0.25	30	18	75	196	Rc1	71	240	146	390	438	155	210	50	—	365	—	413	395	—
$\phi 160$	$\phi 33$	237	132±0.25	35	18	75	210	Rc1	74	253	156	403	454	170	225	55	—	383	—	434	418	—
$\phi 180$	$\phi 33$	265.5	148±0.25	40	20	85	235	Rc1 1/4	75	275	172	445	492	185	243	55	—	415	—	462	455	—
$\phi 200$	$\phi 36$	296	165±0.25	40	25	98	262	Rc1 1/2	85	301	184	497	550	206	272	55	—	454	—	507	494	—
$\phi 224$	$\phi 42$	331	185±0.25	45	30	115	292	Rc1 1/2	89	305	184	535	592	230	310	60	—	480	—	537	525	—
$\phi 250$	$\phi 45$	370.5	208±0.25	50	35	130	325	Rc2	106	346	200	606	672	250	335	65	—	541	—	607	591	—

• The tolerance of B is h8, and that of MM is f8.

### With Boots

Symbol Bore	Rod B	$\phi 32$	$\phi 40$	$\phi 50$	$\phi 63$	$\phi 80$	$\phi 100$	$\phi 125$	$\phi 140$	$\phi 150$	$\phi 160$	$\phi 180$	$\phi 200$	$\phi 224$	$\phi 250$
		WW	Rod C	—	50	50	63	71	80	100	125	125	125	125	140
X	Rod B	45	45	45	55	55	55	65	65	65	65	65	65	80	80
	Rod C	—	45	45	55	55	55	65	65	65	65	65	65	80	80

CAD/DATA  
70-140H-8/TH8  Bore  A. C is available.

### LC

70H-8	1	LC	Bore	B	B	Stroke	-	A	B
140H-8	1	LC	Bore	B	B	Stroke	-	A	B

LC accessory working face ( $\phi 32$  to  $\phi 80$ )

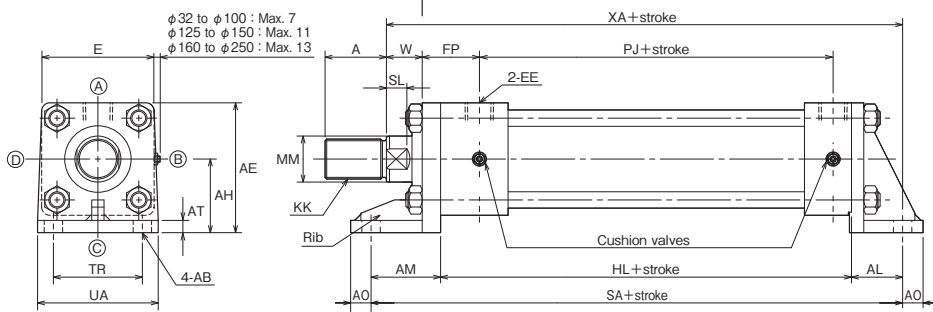
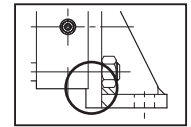

- For dimensions not shown in these figures, refer to the SD style (basic style).
- For the mounting of sensors, refer to the dimensional drawings of "Switch Set." All the contents other than "Sensor mounting dimensions" are the same.
- Cylinders with a bore of 63 mm or less are not provided with ribs.
- If the port size exceeds 1 inch, it is recommended to order G thread or pipe flange. In such a case, contact us. (Order made)
- Note) If the rod clevis (Y-end) is mounted as shown in the following drawing, it may interfere with the rib of the LC accessory. In such a case, consult us.

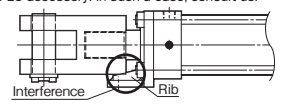

### Double rod type ( $\phi 32$ to $\phi 250$ /rod B or C) for loading on both sides

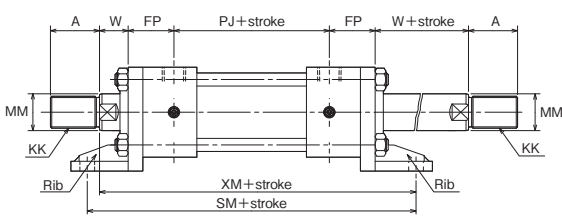

- The Switch Set ( $\phi 32$  to  $\phi 140$ ) is also within the standard stroke range.

### With Boots

70-140H-8/TH8  Bore  K

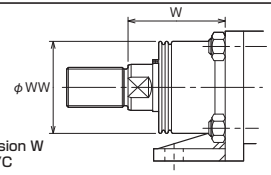

Material	Stroke	W
Nylon tarpaulin Chloroprene	$\phi 32$	1/3 stroke+X
	$\phi 40$ - $\phi 50$	1/3.5 stroke+X
	$\phi 63$ to $\phi 100$	1/4 stroke+X
	$\phi 125$ to $\phi 200$	1/5 stroke+X
Conex	$\phi 224$ to $\phi 250$	1/6 stroke+X
	$\phi 32$	1/2 stroke+X
	$\phi 40$ - $\phi 50$	1/2.5 stroke+X
	$\phi 63$ to $\phi 100$	1/3 stroke+X
	$\phi 125$ - $\phi 140$	1/3.5 stroke+X
	$\phi 150$ to $\phi 200$	1/4 stroke+X
	$\phi 224$ - $\phi 250$	1/4.5 stroke+X

- If the calculated value has a fractional part, round it up.

	Standard	Semi-standard	
Material	Nylon tarpaulin	Chloroprene	Conex
Heat proof	80°C	130°C	200°C

- Notes)
- Remember that the heat proof field in the table above shows the allowable temperatures for the boots, not for the cylinder.
  - Conex is the registered trademark of Teijin Limited.
  - The boots have been mounted at our factory prior to delivery.

### Dimensional Table

Symbol Bore	Rod B							Rod C						
	A	B	KK	MM	S	SL	VD	A	B	KK	MM	S	SL	VD
$\phi 32$	25	$\phi 34$	M16×1.5	$\phi 18$	14	10	10	—	—	—	—	—	—	—
$\phi 40$	30	$\phi 40$	M20×1.5	$\phi 22.4$	19	11	10	25	$\phi 36$	M16×1.5	$\phi 18$	14	10	10
$\phi 50$	35	$\phi 46$	M24×1.5	$\phi 28$	24	14	10	30	$\phi 40$	M20×1.5	$\phi 22.4$	19	11	10
$\phi 63$	45	$\phi 55$	M30×1.5	$\phi 35.5$	30	16	10	35	$\phi 46$	M24×1.5	$\phi 28$	24	14	10
$\phi 80$	60	$\phi 65$	M39×1.5	$\phi 45$	41	20	10	45	$\phi 55$	M30×1.5	$\phi 35.5$	30	16	9
$\phi 100$	75	$\phi 80$	M48×1.5	$\phi 56$	50	23	10	60	$\phi 65$	M39×1.5	$\phi 45$	41	20	10
$\phi 125$	95	$\phi 95$	M64×2	$\phi 71$	65	27	10	75	$\phi 80$	M48×1.5	$\phi 56$	50	23	10
$\phi 140$	110	$\phi 105$	M72×2	$\phi 80$	75	31	10	80	$\phi 85$	M56×2	$\phi 63$	55	24	10
$\phi 150$	115	$\phi 110$	M76×2	$\phi 85$	80	33	10	85	$\phi 90$	M60×2	$\phi 67$	60	30	10
$\phi 160$	120	$\phi 115$	M80×2	$\phi 90$	85	33	10	95	$\phi 95$	M64×2	$\phi 71$	65	27	10
$\phi 180$	140	$\phi 125$	M95×2	$\phi 100$	—	—	10	110	$\phi 105$	M72×2	$\phi 80$	75	31	10
$\phi 200$	150	$\phi 140$	M100×2	$\phi 112$	—	—	10	120	$\phi 115$	M80×2	$\phi 90$	85	33	10
$\phi 224$	180	$\phi 150$	M120×2	$\phi 125$	—	—	10	140	$\phi 125$	M95×2	$\phi 100$	—	—	10
$\phi 250$	195	$\phi 170$	M130×2	$\phi 140$	—	—	10	150	$\phi 140$	M100×2	$\phi 112$	—	—	10

Symbol Bore	AB	AE	AH	AL	AM	AO	AT	E	EE	FP	HL	PJ	SA	TR	UA	W	XA	XM	SM
$\phi 32$	$\phi 11$	69	40±0.15	32	43	13	8	58	Rc3/8	38	130	90	205	40	62	30	203	228	230
$\phi 40$	$\phi 11$	75.5	43±0.15	32	43	13	8	65	Rc3/8	38	130	90	205	46	69	30	203	228	230
$\phi 50$	$\phi 14$	88	50±0.15	35	48	15	8	76	Rc1/2	42	142	98	225	58	85	30	220	247	252
$\phi 63$	$\phi 18$	105	60±0.15	42	57	18	10	90	Rc1/2	46	148	102	247	65	98	35	240	271	278
$\phi 80$	$\phi 18$	127	72±0.25	50	68	20	12	110	Rc3/4	56	166	110	284	87	118	35	269	307	322
$\phi 100$	$\phi 22$	152.5	85±0.25	55	75	23	12	135	Rc3/4	58	172	116	302	109	150	40	287	327	342
$\phi 125$	$\phi 26$	187.5	105±0.25	66	90	29	15	165	Rc1	67	196	130	352	130	175	45	331	375	396
$\phi 140$	$\phi 26$	207.5	115±0.25	70	96	30	18	185	Rc1	69	204	138	370	145	195	50	350	396	416
$\phi 150$	$\phi 30$	221	123±0.25	75	103	30	18	196	Rc1	71	212	146	390	155	210	50	365	413	438
$\phi 160$	$\phi 33$	237	132±0.25	75	106	35	18	210	Rc1	74	222	156	403	170	225	55	383	434	454
$\phi 180$	$\phi 33$	265.5	148±0.25	85	118	40	20	235	Rc1 1/4	75	242	172	445	185	243	55	415	462	492
$\phi 200$	$\phi 36$	296	165±0.25	98	135	40	25	262	Rc1 1/2	85	264	184	497	206	272	55	454	507	550
$\phi 224$	$\phi 42$	331	185±0.25	115	156	45	30	292	Rc1 1/2	89	264	184	535	230	310	60	480	537	592
$\phi 250$	$\phi 45$	370.5	208±0.25	130	176	50	35	325	Rc2	106	300	200	606	250	335	65	541	607	672

- The tolerance of B is h8, and that of MM is f8.

### With Boots

Symbol Bore	Rod	$\phi 32$	$\phi 40$	$\phi 50$	$\phi 63$	$\phi 80$	$\phi 100$	$\phi 125$	$\phi 140$	$\phi 150$	$\phi 160$	$\phi 180$	$\phi 200$	$\phi 224$	$\phi 250$
		WW	Rod B	40	50	63	71	80	100	125	125	140	140	160	180
	Rod C	—	50	50	63	71	80	100	125	125	125	125	140	160	180
X	Rod B	45	45	45	55	55	55	65	65	65	65	65	65	80	80
	Rod C	—	45	45	55	55	55	65	65	65	65	65	65	80	80

CAD/DATA B is available.

### FA for 7MPa

70H-8 1 FA Bore B B Stroke - A B

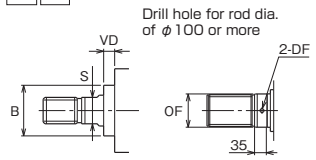

Rod dia.	OF	DF
φ100	φ99.5	φ12
φ112	φ111.5	φ15
φ125	φ124.5	φ15
φ140	φ139.5	φ15

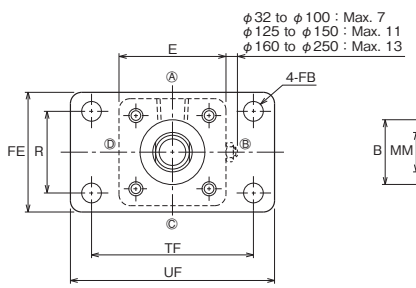

φ32 to φ100 : Max. 7  
φ125 to φ150 : Max. 11  
φ160 to φ250 : Max. 13

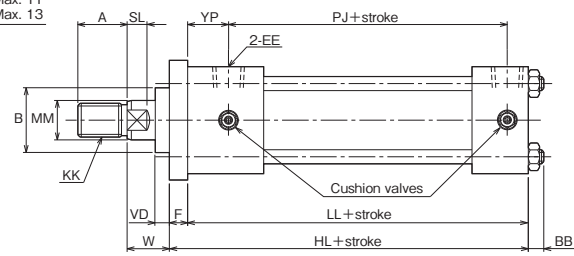

- For dimensions not shown in these figures, refer to the SD style (basic style).
- For the mounting of sensors, refer to the dimensional drawings of "Switch Set." All the contents other than "Sensor mounting dimensions" are the same.
- If the port size exceeds 1 inch, it is recommended to order G thread or pipe flange. In such a case, contact us. (Order made)

### Double rod type (φ32 to φ250/rod B or C) for loading on both sides

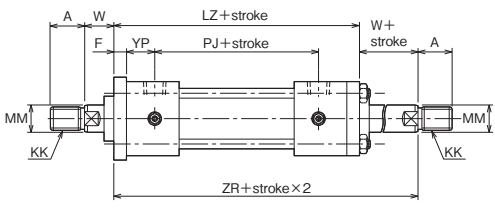

• The Switch Set (φ32 to φ140) is also within the standard stroke range.

### With Boots

70-140H-8/TH8 K

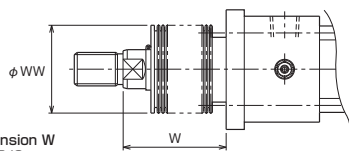

Material	Stroke	W
Nylon tarpaulin Chloroprene	φ32	1/3 stroke+X
	φ40-φ50	1/3.5 stroke+X
	φ63 to φ100	1/4 stroke+X
	φ125 to φ200	1/5 stroke+X
	φ224 to φ250	1/6 stroke+X
Conex	φ32	1/2 stroke+X
	φ40-φ50	1/2.5 stroke+X
	φ63 to φ100	1/3 stroke+X
	φ125-φ140	1/3.5 stroke+X
	φ150 to φ200	1/4 stroke+X
φ224-φ250	1/4.5 stroke+X	

• If the calculated value has a fractional part, round it up.

	Standard	Semi-standard	
Material	Nylon tarpaulin	Chloroprene	Conex
Heat proof	80°C	130°C	200°C

- Notes
- Remember that the heat proof field in the table above shows the allowable temperatures for the boots, not for the cylinder.
  - Conex is the registered trademark of Teijin Limited.
  - The boots have been mounted at our factory prior to delivery.

### Dimensional Table

Symbol Bore	Rod B							Rod C						
	A	B	KK	MM	S	SL	VD	A	B	KK	MM	S	SL	VD
φ32	25	φ34	M16×1.5	φ18	14	10	10	—	—	—	—	—	—	—
φ40	30	φ40	M20×1.5	φ22.4	19	11	10	25	φ36	M16×1.5	φ18	14	10	10
φ50	35	φ46	M24×1.5	φ28	24	14	10	30	φ40	M20×1.5	φ22.4	19	11	10
φ63	45	φ55	M30×1.5	φ35.5	30	16	10	35	φ46	M24×1.5	φ28	24	14	10
φ80	60	φ65	M39×1.5	φ45	41	20	10	45	φ55	M30×1.5	φ35.5	30	16	9
φ100	75	φ80	M48×1.5	φ56	50	23	10	60	φ65	M39×1.5	φ45	41	20	10
φ125	95	φ95	M64×2	φ71	65	27	10	75	φ80	M48×1.5	φ56	50	23	10
φ140	110	φ105	M72×2	φ80	75	31	10	80	φ85	M56×2	φ63	55	24	10
φ150	115	φ110	M76×2	φ85	80	33	10	85	φ90	M60×2	φ67	60	30	10
φ160	120	φ115	M80×2	φ90	85	33	10	95	φ95	M64×2	φ71	65	27	10
φ180	140	φ125	M95×2	φ100	—	—	10	110	φ105	M72×2	φ80	75	31	10
φ200	150	φ140	M100×2	φ112	—	—	10	120	φ115	M80×2	φ90	85	33	10
φ224	180	φ150	M120×2	φ125	—	—	10	140	φ125	M95×2	φ100	—	—	10
φ250	195	φ170	M130×2	φ140	—	—	10	150	φ140	M100×2	φ112	—	—	10

Symbol Bore	BB	E	EE	F	FB	FE	HL	LL	LZ	PJ	R	TF	UF	W	YP	ZR
φ32	11	□58	Rc3/8	11	φ11	62	141	130	166	90	40	88	109	30	27	196
φ40	11	□65	Rc3/8	11	φ11	69	141	130	166	90	46	95	118	30	27	196
φ50	11	□76	Rc1/2	13	φ14	85	155	142	182	98	58	115	145	30	29	212
φ63	13	□90	Rc1/2	15	φ18	98	163	148	194	102	65	132	165	35	31	229
φ80	16	□110	Rc3/4	18	φ18	118	184	166	222	110	87	155	190	35	38	257
φ100	18	□135	Rc3/4	20	φ22	150	192	172	232	116	109	190	230	40	38	272
φ125	21	□165	Rc1	24	φ26	175	220	196	264	130	130	224	272	45	43	309
φ140	22	□185	Rc1	26	φ26	195	230	204	276	138	145	250	300	50	43	326
φ150	25	□196	Rc1	28	φ30	210	240	212	288	146	155	270	320	50	43	338
φ160	25	□210	Rc1	31	φ33	225	253	222	304	156	170	285	345	55	43	359
φ180	27	□235	Rc1 1/4	33	φ33	243	275	242	322	172	185	315	375	55	42	377
φ200	29	□262	Rc1 1/2	37	φ36	272	301	264	354	184	206	355	425	55	48	409
φ224	34	□292	Rc1 1/2	41	φ42	310	305	264	362	184	230	395	475	60	48	422
φ250	37	□325	Rc2	46	φ45	335	346	300	412	200	250	425	515	65	60	477

• The tolerance of B is h8, and that of MM is f8.

### With Boots

Symbol Bore	WW	φ32	φ40	φ50	φ63	φ80	φ100	φ125	φ140	φ150	φ160	φ180	φ200	φ224	φ250
		Rod B	40	50	63	71	80	100	125	125	140	140	160	180	180
Rod C	—	50	50	63	71	80	100	125	125	125	125	140	160	180	
X	Rod B	45	45	45	55	55	55	65	65	65	65	65	65	80	80
	Rod A	—	45	45	55	55	55	65	65	65	65	65	65	80	80

CAD/DATA is available.

70-140H-8/TH8 A. C

### FK

70H-8	1	FK	Bore	B	B	Stroke	-	A	B
140H-8	1	FK	Bore	B	B	Stroke	-	A	B

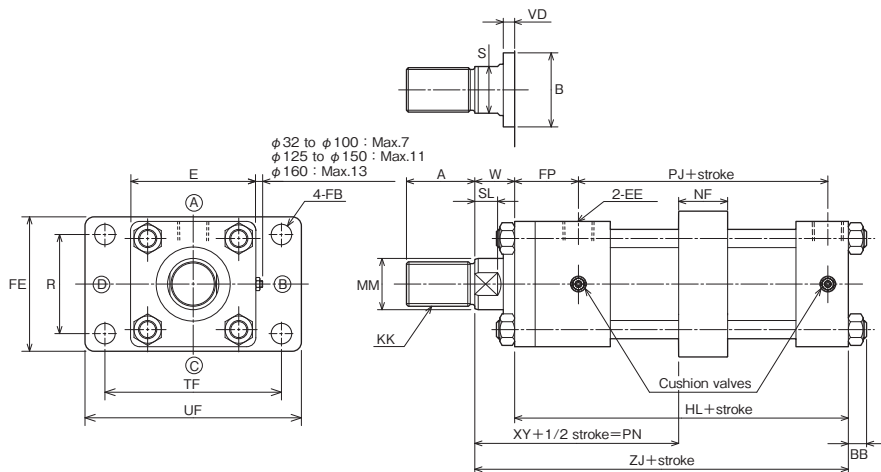

- For dimensions not shown in these figures, refer to the SD style (basic style).
- For the mounting of sensors, refer to the dimensional drawings of "Switch Set." All the contents other than "Sensor mounting dimensions" and "Minimum dimension PN of Switch Set Cylinders" are the same.

### With Boots

70-140H-8/TH8 K

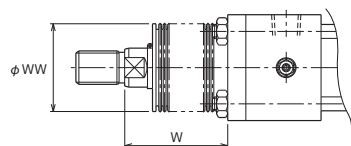

	Standard	Semi-standard	
Material	Nylon tarpaulin	Chloroprene	Conex
Heat proof	80°C	130°C	200°C

Notes)

- Remember that the heat proof field in the table above shows the allowable temperatures for the boots, not for the cylinder.
- Conex is the registered trademark of Teijin Limited.
- If the calculated value has a fractional part, round it up.
- The boots have been mounted at our factory prior to delivery.

Dimension W

Material	Stroke	W
Nylon tarpaulin Chloroprene	φ32	1/3 stroke+X
	φ40 · φ50	1/3.5 stroke+X
	φ63 to φ100	1/4 stroke+X
	φ125 to φ160	1/5 stroke+X
Conex	φ32	1/2 stroke+X
	φ40 · φ50	1/2.5 stroke+X
	φ63 to φ100	1/3 stroke+X
	φ125 · φ140	1/3.5 stroke+X
	φ150 to φ160	1/4 stroke+X

Rod A

Material	Stroke	W
Nylon tarpaulin Chloroprene	φ40	1/3.5 stroke+X
	φ50 to φ80	1/4 stroke+X
	φ100 to φ160	1/5 stroke+X
Conex	φ40	1/2.5 stroke+X
	φ50 to φ80	1/3 stroke+X
	φ100	1/3.5 stroke+X
	φ125 to φ160	1/4 stroke+X

### Dimensional Table

Symbol Bore	Rod B							Rod C							Rod A							
	A	B	KK	MM	S	SL	VD	A	B	KK	MM	S	SL	VD	A	B	KK	MM	S	SL	VD	
φ32	25	φ34	M16×1.5	φ18	14	10	10	—	—	—	—	—	—	—	—	—	—	—	—	—	—	—
φ40	30	φ40	M20×1.5	φ22.4	19	11	10	25	φ36	M16×1.5	φ18	14	10	10	35	φ43	M24×1.5	φ28	24	14	17	—
φ50	35	φ46	M24×1.5	φ28	24	14	10	30	φ40	M20×1.5	φ22.4	19	11	10	45	φ50	M30×1.5	φ35.5	30	16	17	—
φ63	45	φ55	M30×1.5	φ35.5	30	16	10	35	φ46	M24×1.5	φ28	24	14	10	60	φ65	M39×1.5	φ45	41	20	19	—
φ80	60	φ65	M39×1.5	φ45	41	20	10	45	φ55	M30×1.5	φ35.5	30	16	9	75	φ80	M48×1.5	φ56	50	23	20	—
φ100	75	φ80	M48×1.5	φ56	50	23	10	60	φ65	M39×1.5	φ45	41	20	10	95	φ95	M64×2	φ71	65	27	23	—
φ125	95	φ95	M64×2	φ71	65	27	10	75	φ80	M48×1.5	φ56	50	23	10	120	φ115	M80×2	φ90	85	33	17	—
φ140	110	φ105	M72×2	φ80	75	31	10	80	φ85	M56×2	φ63	55	24	10	140	φ125	M95×2	φ100	—	—	Drill hole	17
φ150	115	φ110	M76×2	φ85	80	33	10	85	φ90	M60×2	φ67	60	30	10	140	φ125	M95×2	φ100	—	—	Drill hole	15
φ160	120	φ115	M80×2	φ90	85	33	10	95	φ95	M64×2	φ71	65	27	10	150	φ140	M100×2	φ112	—	—	Drill hole	16

Symbol Bore	BB	E	EE	FB	FE	FP	HL	NF	PJ	Min. PN		R	TF	UF	W		XY		ZJ	
										B.C	A				B.C	A	B.C	A		
φ32	11	□58	Rc3/8	φ11	62	38	141	28	90	91	—	40	88	109	30	—	99	—	171	—
φ40	11	□65	Rc3/8	φ11	69	38	141	28	90	91	96	46	95	118	30	35	99	104	171	176
φ50	11	□76	Rc1/2	φ14	85	42	155	33	98	97	108	58	115	145	30	41	104.5	115.5	185	196
φ63	13	□90	Rc1/2	φ18	98	46	163	43	102	106	119	65	132	165	35	48	110.5	123.5	198	211
φ80	16	□110	Rc3/4	φ18	118	56	184	43	110	119	135	87	155	190	35	51	124.5	140.5	219	235
φ100	18	□135	Rc3/4	φ22	150	58	192	53	116	126	143	109	190	230	40	57	129.5	146.5	232	249
φ125	21	□165	Rc1	φ26	175	67	220	58	130	145	157	130	224	272	45	57	148	160	265	277
φ140	22	□185	Rc1	φ26	195	69	230	78	138	152	159	145	250	300	50	57	149	156	280	287
φ150	25	□196	Rc1	φ30	210	71	240	78	146	154	161	155	270	320	50	57	155	162	290	297
φ160	25	□210	Rc1	φ33	225	74	253	88	156	167	169	170	285	345	55	57	163	165	308	310

- The tolerance of B is h8, and that of MM is f8.

### With Boots

Symbol Bore	Rod	φ32	φ40	φ50	φ63	φ80	φ100	φ125	φ140	φ150	φ160
		WW	Rod B	40	50	63	71	80	100	125	125
X	Rod C	—	50	50	63	71	80	100	125	125	125
	Rod A	—	63	71	80	100	125	140	160	160	180
X	Rod B	45	45	45	55	55	55	65	65	65	65
	Rod C	—	45	45	55	55	55	65	65	65	65
	Rod A	—	45	55	55	55	65	65	65	65	65

CAD/DATA is available.

70-140H-8/TH8 B

### FB for 7MPa

-

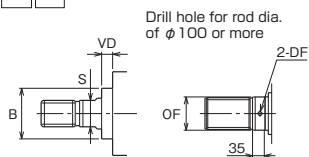

Rod dia.	OF	DF
φ100	φ99.5	φ12
φ112	φ111.5	φ15
φ125	φ124.5	φ15
φ140	φ139.5	φ15

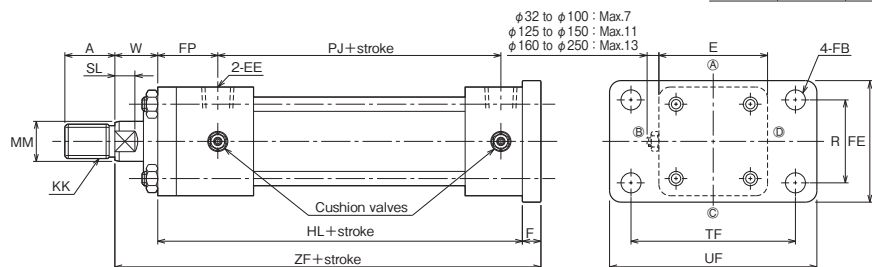

- For dimensions not shown in these figures, refer to the SD style (basic style).
- For the mounting of sensors, refer to the dimensional drawings of "Switch Set." All the contents other than "Sensor mounting dimensions" are the same.
- If the port size exceeds 1 inch, it is recommended to order G thread or pipe flange. In such a case, contact us. (Order made)

### Double rod type (φ32 to φ250/rod B or C) for loading on both sides

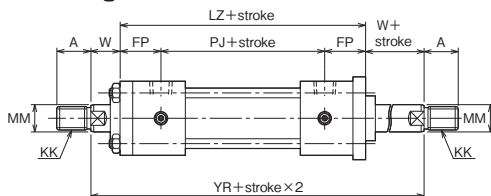

- The Switch Set (φ32 to φ140) is also within the standard stroke range.

### With Boots

70-140H-8/TH8 K

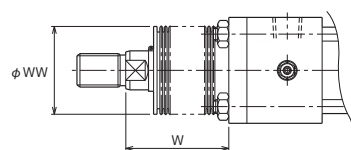

	Standard	Semi-standard	
Material	Nylon tarpaulin	Chloroprene	Conex
Heat proof	80°C	130°C	200°C

#### Notes

- Remember that the heat proof field in the table above shows the allowable temperatures for the boots, not for the cylinder.
- Conex is the registered trademark of Teijin Limited.
- If the calculated value has a fractional part, round it up.
- The boots have been mounted at our factory prior to delivery.

#### Dimension W

Rod B/C	Material	Stroke	W
Nylon tarpaulin Chloroprene		φ32 1/3 stroke+X	1/3 stroke+X
		φ40·φ50 1/3.5 stroke+X	1/3.5 stroke+X
		φ63 to φ100 1/4 stroke+X	1/4 stroke+X
		φ125 to φ200 1/5 stroke+X	1/5 stroke+X
Conex		φ224 to φ250 1/6 stroke+X	1/6 stroke+X
		φ32 1/2 stroke+X	1/2 stroke+X
		φ40·φ50 1/2.5 stroke+X	1/2.5 stroke+X
		φ63 to φ100 1/3 stroke+X	1/3 stroke+X
Conex		φ125·φ140 1/3.5 stroke+X	1/3.5 stroke+X
		φ150 to φ200 1/4 stroke+X	1/4 stroke+X
		φ224·φ250 1/4.5 stroke+X	1/4.5 stroke+X
		φ40 1/2.5 stroke+X	1/2.5 stroke+X
Conex		φ50 to φ80 1/3 stroke+X	1/3 stroke+X
		φ100 1/3.5 stroke+X	1/3.5 stroke+X
		φ125 to φ160 1/4 stroke+X	1/4 stroke+X
		φ125 to φ160 1/4 stroke+X	1/4 stroke+X

#### Rod A

Material	Stroke	W
Nylon tarpaulin Chloroprene	φ40 1/3.5 stroke+X	1/3.5 stroke+X
	φ50 to φ80 1/4 stroke+X	1/4 stroke+X
Conex	φ100 to φ160 1/5 stroke+X	1/5 stroke+X
	φ40 1/2.5 stroke+X	1/2.5 stroke+X
	φ50 to φ80 1/3 stroke+X	1/3 stroke+X
	φ100 1/3.5 stroke+X	1/3.5 stroke+X
Conex	φ125 to φ160 1/4 stroke+X	1/4 stroke+X
	φ125 to φ160 1/4 stroke+X	1/4 stroke+X

### Dimensional Table

Symbol Bore	Rod B							Rod C							Rod A							
	A	B	KK	MM	S	SL	VD	A	B	KK	MM	S	SL	VD	A	B	KK	MM	S	SL	VD	
φ32	25	φ34	M16×1.5	φ18	14	10	10	—	—	—	—	—	—	—	—	—	—	—	—	—	—	—
φ40	30	φ40	M20×1.5	φ22.4	19	11	10	25	φ36	M16×1.5	φ18	14	10	10	35	φ43	M24×1.5	φ28	24	14	17	—
φ50	35	φ46	M24×1.5	φ28	24	14	10	30	φ40	M20×1.5	φ22.4	19	11	10	45	φ50	M30×1.5	φ35.5	30	16	17	—
φ63	45	φ55	M30×1.5	φ35.5	30	16	10	35	φ46	M24×1.5	φ28	24	14	10	60	φ65	M39×1.5	φ45	41	20	19	—
φ80	60	φ65	M39×1.5	φ45	41	20	10	45	φ55	M30×1.5	φ35.5	30	16	9	75	φ80	M48×1.5	φ56	50	23	20	—
φ100	75	φ80	M48×1.5	φ56	50	23	10	60	φ65	M39×1.5	φ45	41	20	10	95	φ95	M64×2	φ71	65	27	23	—
φ125	95	φ95	M64×2	φ71	65	27	10	75	φ80	M48×1.5	φ56	50	23	10	120	φ115	M80×2	φ90	85	33	17	—
φ140	110	φ105	M72×2	φ80	75	31	10	80	φ85	M56×2	φ63	55	24	10	140	φ125	M95×2	φ100	—	—	—	Drill hole
φ150	115	φ110	M76×2	φ85	80	33	10	85	φ90	M60×2	φ67	60	30	10	140	φ125	M95×2	φ100	—	—	—	15
φ160	120	φ115	M80×2	φ90	85	33	10	95	φ95	M64×2	φ71	65	27	10	150	φ140	M100×2	φ112	—	—	—	Drill hole
φ180	140	φ125	M95×2	φ100	—	—	10	110	φ105	M72×2	φ80	75	31	10	—	—	—	—	—	—	—	—
φ200	150	φ140	M100×2	φ112	—	—	10	120	φ115	M80×2	φ90	85	33	10	—	—	—	—	—	—	—	—
φ224	180	φ150	M120×2	φ125	—	—	10	140	φ125	M95×2	φ100	—	—	10	—	—	—	—	—	—	—	—
φ250	195	φ170	M130×2	φ140	—	—	10	150	φ140	M100×2	φ112	—	—	10	—	—	—	—	—	—	—	—

Symbol Bore	E	EE	F	FB	FE	FP	HL	LZ	PJ	R	TF	UF	W		YR	ZF	
													B·C	A		B·C	A
φ32	□58	Rc3/8	11	φ11	62	38	141	166	90	40	88	109	30	—	226	182	—
φ40	□65	Rc3/8	11	φ11	69	38	141	166	90	46	95	118	30	35	226	182	187
φ50	□76	Rc1/2	13	φ14	85	42	155	182	98	58	115	145	30	41	242	198	209
φ63	□90	Rc1/2	15	φ18	98	46	163	194	102	65	132	165	35	48	264	213	226
φ80	□110	Rc3/4	18	φ18	118	56	184	222	110	87	155	190	35	51	292	237	253
φ100	□135	Rc3/4	20	φ22	150	58	192	232	116	109	190	230	40	57	312	252	269
φ125	□165	Rc1	24	φ26	175	67	220	264	130	130	224	272	45	57	354	289	301
φ140	□185	Rc1	26	φ26	195	69	230	276	138	145	250	300	50	57	376	306	313
φ150	□196	Rc1	28	φ30	210	71	240	288	146	155	270	320	50	57	388	318	325
φ160	□210	Rc1	31	φ33	225	74	253	304	156	170	285	345	55	57	414	339	341
φ180	□235	Rc1 1/4	33	φ33	243	75	275	322	172	185	315	375	55	—	432	363	—
φ200	□262	Rc1 1/2	37	φ36	272	85	301	354	184	206	355	425	55	—	464	393	—
φ224	□292	Rc1 1/2	41	φ42	310	89	305	362	184	230	395	475	60	—	482	406	—
φ250	□325	Rc2	46	φ45	335	106	346	412	200	250	425	515	65	—	542	457	—

- The tolerance of B is h8, and that of MM is f8.

### With Boots

Symbol Bore	Rod	φ32	φ40	φ50	φ63	φ80	φ100	φ125	φ140	φ150	φ160	φ180	φ200	φ224	φ250
		WW	Rod B	40	50	63	71	80	100	125	125	140	140	160	180
X	Rod C	—	50	50	63	71	80	100	125	125	125	125	140	160	180
	Rod A	—	63	71	80	100	125	140	160	160	180	—	—	—	—
X	Rod B	45	45	45	55	55	55	65	65	65	65	65	65	80	80
	Rod C	—	45	45	55	55	55	65	65	65	65	65	65	80	80
	Rod A	—	45	55	55	55	65	65	65	65	65	—	—	—	—

70-140H-8/TH8 [Bore] C CAD/DATA is available.

### FE for rod A

70H-8	1	FE	Bore	A	B	Stroke	-	A	B
140H-8	1	FE	Bore	A	B	Stroke	-	A	B

Drill hole for rod dia. of  $\phi$  100 or more

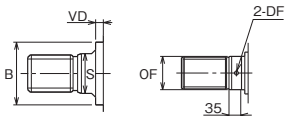

Rod dia.	OF	DF
$\phi$ 100	$\phi$ 99.5	$\phi$ 12
$\phi$ 112	$\phi$ 111.5	$\phi$ 15

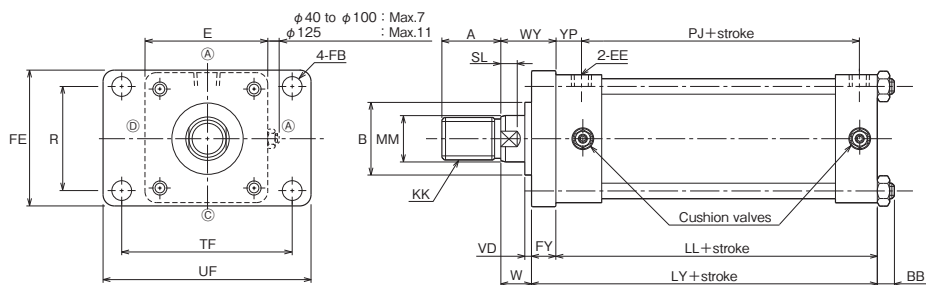

• For dimensions not shown in these figures, refer to the SD style (basic style).

### With Boots

70-140H-8/TH8 [Bore] K

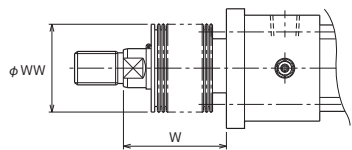

Dimension W  
Rod A

Nylon tarpaulin	$\phi$ 40	1/3.5	stroke+X
Chloroprene	$\phi$ 50 to $\phi$ 80	1/4	stroke+X
	$\phi$ 100 to $\phi$ 160	1/5	stroke+X
Conex	$\phi$ 40	1/2.5	stroke+X
	$\phi$ 50 to $\phi$ 80	1/3	stroke+X
	$\phi$ 100	1/3.5	stroke+X
	$\phi$ 125 to $\phi$ 160	1/4	stroke+X

	Standard	Semi-standard	
Material	Nylon tarpaulin	Chloroprene	Conex
Heat proof	80°C	130°C	200°C

Notes)

- Remember that the heat proof field in the table above shows the allowable temperatures for the boots, not for the cylinder.
- Conex is the registered trademark of Teijin Limited.
- If the calculated value has a fractional part, round it up.
- The boots have been mounted at our factory prior to delivery.

### Dimensional Table

Symbol Bore	Rod A							BB	E	EE	FB	FE	FY	LL	LY	PJ	R	TF	UF	W	WY	YP
	A	B	KK	MM	S	SL	VD															
$\phi$ 40	35	$\phi$ 43	M24 $\times$ 1.5	$\phi$ 28	24	14	10	11	$\square$ 65	Rc3/8	$\phi$ 11	69	18	130	148	90	46	95	118	35	53	27
$\phi$ 50	45	$\phi$ 50	M30 $\times$ 1.5	$\phi$ 35.5	30	16	10	11	$\square$ 76	Rc1/2	$\phi$ 14	85	20	142	162	98	58	115	145	41	61	29
$\phi$ 63	60	$\phi$ 65	M39 $\times$ 1.5	$\phi$ 45	41	20	10	13	$\square$ 90	Rc1/2	$\phi$ 18	98	24	148	172	102	65	132	165	48	72	31
$\phi$ 80	75	$\phi$ 80	M48 $\times$ 1.5	$\phi$ 56	50	23	8	16	$\square$ 110	Rc3/4	$\phi$ 18	118	30	166	196	110	87	155	190	51	81	38
$\phi$ 100	95	$\phi$ 95	M64 $\times$ 2	$\phi$ 71	65	27	11	18	$\square$ 135	Rc3/4	$\phi$ 22	150	32	172	204	116	109	190	230	57	89	38
$\phi$ 125	120	$\phi$ 115	M80 $\times$ 2	$\phi$ 90	85	33	10	21	$\square$ 165	Rc1	$\phi$ 26	175	41	196	237	130	130	224	272	57	98	43
$\phi$ 140	140	$\phi$ 125	M95 $\times$ 2	$\phi$ 100	-	-	13	22	$\square$ 185	Rc1	$\phi$ 26	195	43	204	247	138	145	250	300	57	100	43
$\phi$ 150	140	$\phi$ 125	M95 $\times$ 2	$\phi$ 100	-	-	13	25	$\square$ 196	Rc1	$\phi$ 30	210	43	212	255	146	155	270	320	57	100	43
$\phi$ 160	150	$\phi$ 140	M100 $\times$ 2	$\phi$ 112	-	-	15	25	$\square$ 210	Rc1	$\phi$ 33	225	46	222	268	156	170	285	345	57	103	43

• The tolerance of B is h8, and that of MM is f8.

### With Boots

Symbol Bore	Rod A									
	$\phi$ 40	$\phi$ 50	$\phi$ 63	$\phi$ 80	$\phi$ 100	$\phi$ 125	$\phi$ 140	$\phi$ 150	$\phi$ 160	
WW	63	71	80	100	125	140	160	160	180	
X	45	55	55	55	65	65	65	65	65	

CAD/DATA is available.

70-140H-8/TH8 B

### FY

70H-8	1	FY	Bore	B	B	Stroke	A	B
140H-8	1	FY	Bore	B	B	Stroke	A	B

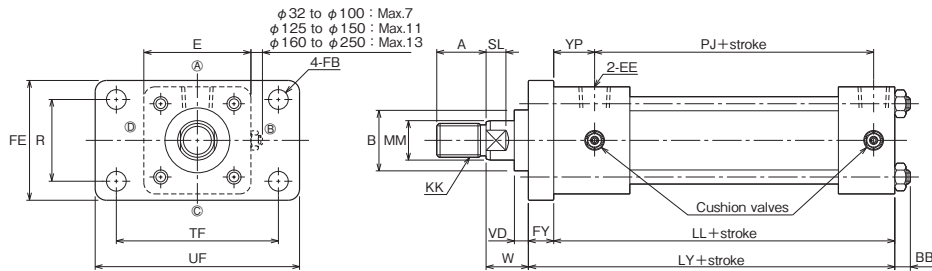
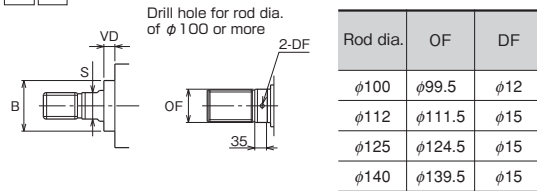

- For dimensions not shown in these figures, refer to the SD style (basic style).
- For the mounting of sensors, refer to the dimensional drawings of "Switch Set." All the contents other than "Sensor mounting dimensions" are the same.
- If the port size exceeds 1 inch, it is recommended to order G thread or pipe flange. In such a case, contact us. (Order made)

### Double rod type (φ32 to φ250/rod B or C) for loading on both sides

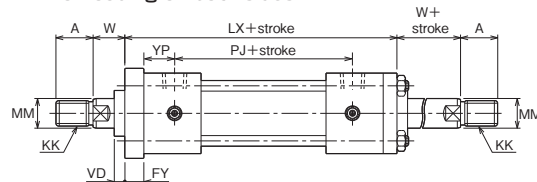

• The Switch Set (φ32 to φ140) is also within the standard stroke range.

### With Boots

70-140H-8/TH8 K

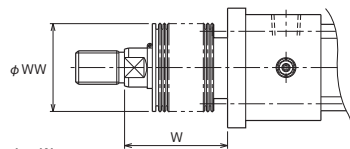

Material	φ32	φ40	φ50	φ63	φ80	φ100	φ125	φ140	φ150	φ160	φ180	φ200	φ224	φ250
Nylon tarpaulin	1/3	1/3.5	1/4	1/5	1/5	1/5	1/5	1/5	1/5	1/5	1/5	1/5	1/5	1/5
Chloroprene	1/3	1/3.5	1/4	1/5	1/5	1/5	1/5	1/5	1/5	1/5	1/5	1/5	1/5	1/5
Conex	1/2	1/2.5	1/3	1/3.5	1/4	1/4	1/4	1/4	1/4	1/4	1/4	1/4	1/4	1/4.5

	Standard	Semi-standard	
Material	Nylon tarpaulin	Chloroprene	Conex
Heat proof	80°C	130°C	200°C

#### Notes)

- Remember that the heat proof field in the table above shows the allowable temperatures for the boots, not for the cylinder.
- Conex is the registered trademark of Teijin Limited.
- If the calculated value has a fractional part, round it up.
- The boots have been mounted at our factory prior to delivery.

### Dimensional Table

Symbol Bore	Rod B							Rod C						
	A	B	KK	MM	S	SL	VD	A	B	KK	MM	S	SL	VD
φ32	25	φ34	M16×1.5	φ18	14	10	10	—	—	—	—	—	—	—
φ40	30	φ40	M20×1.5	φ22.4	19	11	10	25	φ36	M16×1.5	φ18	14	10	10
φ50	35	φ46	M24×1.5	φ28	24	14	10	30	φ40	M20×1.5	φ22.4	19	11	10
φ63	45	φ55	M30×1.5	φ35.5	30	16	10	35	φ46	M24×1.5	φ28	24	14	10
φ80	60	φ65	M39×1.5	φ45	41	20	10	45	φ55	M30×1.5	φ35.5	30	16	10
φ100	75	φ80	M48×1.5	φ56	50	23	10	60	φ65	M39×1.5	φ45	41	20	10
φ125	95	φ95	M64×2	φ71	65	27	10	75	φ80	M48×1.5	φ56	50	23	10
φ140	110	φ105	M72×2	φ80	75	31	10	80	φ85	M56×2	φ63	55	24	10
φ150	115	φ110	M76×2	φ85	80	33	10	85	φ90	M60×2	φ67	60	30	10
φ160	120	φ115	M80×2	φ90	85	33	10	95	φ95	M64×2	φ71	65	27	10
φ180	140	φ125	M95×2	φ100	—	—	10	110	φ105	M72×2	φ80	75	31	10
φ200	150	φ140	M100×2	φ112	—	—	10	120	φ115	M80×2	φ90	85	33	10
φ224	180	φ150	M120×2	φ125	—	—	10	140	φ125	M95×2	φ100	—	—	10
φ250	195	φ170	M130×2	φ140	—	—	10	150	φ140	M100×2	φ112	—	—	10

Symbol Bore	BB	E	EE	FB	FE	FY	LL	LX	LY	PJ	R	TF	UF	W	YP
φ32	11	□58	Rc3/8	φ11	62	13	130	168	143	90	40	88	109	30	27
φ40	11	□65	Rc3/8	φ11	69	13	130	168	143	90	46	95	118	30	27
φ50	11	□76	Rc1/2	φ14	85	18	142	187	160	98	58	115	145	30	29
φ63	13	□90	Rc1/2	φ18	98	20	148	199	168	102	65	132	165	35	31
φ80	16	□110	Rc3/4	φ18	118	24	166	228	190	110	87	155	190	35	38
φ100	18	□135	Rc3/4	φ22	150	28	172	240	200	116	109	190	230	40	38
φ125	21	□165	Rc1	φ26	175	33	196	273	229	130	130	224	272	45	43
φ140	22	□185	Rc1	φ26	195	37	204	287	241	138	145	250	300	50	43
φ150	25	□196	Rc1	φ30	210	39	212	299	251	146	155	270	320	50	43
φ160	25	□210	Rc1	φ33	225	41	222	314	263	156	170	285	345	55	43
φ180	27	□235	Rc1 <sup>1/4</sup>	φ33	243	46	242	335	288	172	185	315	375	55	42
φ200	29	□262	Rc1 <sup>1/2</sup>	φ36	272	51	264	368	315	184	206	355	425	55	48
φ224	34	□292	Rc1 <sup>1/2</sup>	φ42	310	58	264	379	322	184	230	395	475	60	48
φ250	37	□325	Rc2	φ45	335	65	300	431	365	200	250	425	515	65	60

• The tolerance of B is h8, and that of MM is f8.

### With Boots

Symbol Bore	Rod	φ32	φ40	φ50	φ63	φ80	φ100	φ125	φ140	φ150	φ160	φ180	φ200	φ224	φ250
		WW	Rod B	40	50	63	71	80	100	125	125	140	140	160	180
	Rod C	—	50	50	63	71	80	100	125	125	125	125	140	160	180
X	Rod B	45	45	45	55	55	55	65	65	65	65	65	65	80	80
	Rod C	—	45	45	55	55	55	65	65	65	65	65	65	80	80

CAD/DATA is available.

70-140H-8/TH8 B, C

### FZ

70H-8	1	FZ		B	B	Stroke	-	A	B
140H-8	1	FZ		B	B	Stroke	-	A	B

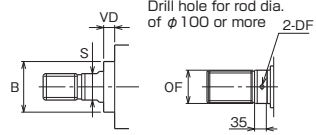

Rod dia.	OF	DF
φ100	φ99.5	φ12
φ112	φ111.5	φ15
φ125	φ124.5	φ15
φ140	φ139.5	φ15

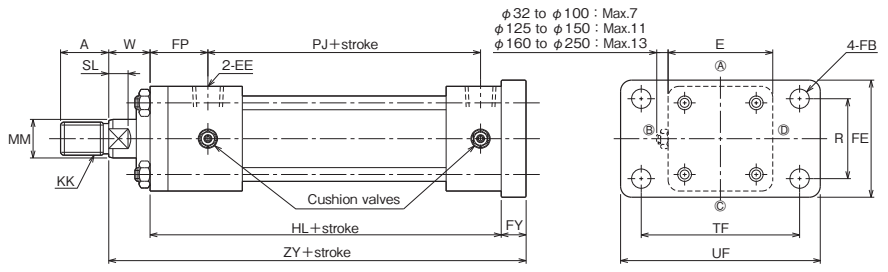

- For dimensions not shown in these figures, refer to the SD style (basic style).
- For the mounting of sensors, refer to the dimensional drawings of "Switch Set." All the contents other than "Sensor mounting dimensions" are the same.
- If the port size exceeds 1 inch, it is recommended to order G thread or pipe flange. In such a case, contact us. (Order made)

### Double rod type (φ32 to φ250/rod B or C) for loading on both sides

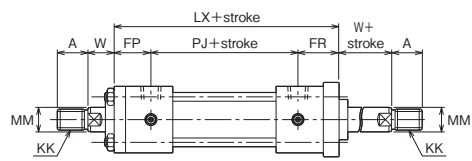

- The Switch Set (φ32 to φ140) is also within the standard stroke range.

### With Boots

70-140H-8/TH8 K

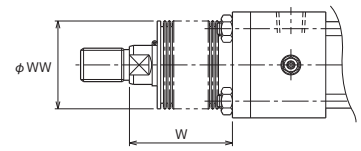

	Standard	Semi-standard	
Material	Nylon tarpaulin	Chloroprene	Conex
Heat proof	80°C	130°C	200°C

- Notes
- Remember that the heat proof field in the table above shows the allowable temperatures for the boots, not for the cylinder.
  - Conex is the registered trademark of Teijin Limited.
  - The boots have been mounted at our factory prior to delivery.

Dimension W	Rod B/C		
Nylon tarpaulin Chloroprene		φ32	1/3 stroke+X
		φ40-φ50	1/3.5 stroke+X
		φ63 to φ100	1/4 stroke+X
		φ125 to φ200	1/5 stroke+X
Conex		φ224 to φ250	1/6 stroke+X
		φ32	1/2 stroke+X
		φ40-φ50	1/2.5 stroke+X
		φ63 to φ100	1/3 stroke+X
Conex		φ125-φ140	1/3.5 stroke+X
		φ150 to φ200	1/4 stroke+X
		φ224 · φ250	1/4.5 stroke+X
		φ40	1/2.5 stroke+X
Nylon tarpaulin Chloroprene		φ50 to φ80	1/4 stroke+X
		φ100 to φ160	1/5 stroke+X
		φ40	1/2.5 stroke+X
		φ50 to φ80	1/3 stroke+X
Conex		φ100	1/3.5 stroke+X
		φ125 to φ160	1/4 stroke+X
		φ125 to φ160	1/4 stroke+X

- If the calculated value has a fractional part, round it up.

### Dimensional Table

Symbol Bore	Rod B							Rod C							Rod A							
	A	B	KK	MM	S	SL	VD	A	B	KK	MM	S	SL	VD	A	B	KK	MM	S	SL	VD	
φ32	25	φ34	M16×1.5	φ18	14	10	10	—	—	—	—	—	—	—	—	—	—	—	—	—	—	—
φ40	30	φ40	M20×1.5	φ22.4	19	11	10	25	φ36	M16×1.5	φ18	14	10	10	35	φ43	M24×1.5	φ28	24	14	17	—
φ50	35	φ46	M24×1.5	φ28	24	14	10	30	φ40	M20×1.5	φ22.4	19	11	10	45	φ50	M30×1.5	φ35.5	30	16	17	—
φ63	45	φ55	M30×1.5	φ35.5	30	16	10	35	φ46	M24×1.5	φ28	24	14	10	60	φ65	M39×1.5	φ45	41	20	19	—
φ80	60	φ65	M39×1.5	φ45	41	20	10	45	φ55	M30×1.5	φ35.5	30	16	9	75	φ80	M48×1.5	φ56	50	23	20	—
φ100	75	φ80	M48×1.5	φ56	50	23	10	60	φ65	M39×1.5	φ45	41	20	10	95	φ95	M64×2	φ71	65	27	23	—
φ125	95	φ95	M64×2	φ71	65	27	10	75	φ80	M48×1.5	φ56	50	23	10	120	φ115	M80×2	φ90	85	33	17	—
φ140	110	φ105	M72×2	φ80	75	31	10	80	φ85	M56×2	φ63	55	24	10	140	φ125	M95×2	φ100	—	—	17	—
φ150	115	φ110	M76×2	φ85	80	33	10	85	φ90	M60×2	φ67	60	30	10	140	φ125	M95×2	φ100	—	—	15	—
φ160	120	φ115	M80×2	φ90	85	33	10	95	φ95	M64×2	φ71	65	27	10	150	φ140	M100×2	φ112	—	—	16	—
φ180	140	φ125	M95×2	φ100	—	—	10	110	φ105	M72×2	φ80	75	31	10	—	—	—	—	—	—	—	—
φ200	150	φ140	M100×2	φ112	—	—	10	120	φ115	M80×2	φ90	85	33	10	—	—	—	—	—	—	—	—
φ224	180	φ150	M120×2	φ125	—	—	10	140	φ125	M95×2	φ100	—	—	10	—	—	—	—	—	—	—	—
φ250	195	φ170	M130×2	φ140	—	—	10	150	φ140	M100×2	φ112	—	—	10	—	—	—	—	—	—	—	—

Symbol Bore	E	EE	FB	FE	FP	FR	FY	HL	LX	PJ	R	TF	UF	W		ZY	
														B·C	A	B·C	A
φ32	□58	Rc3/8	φ11	62	38	40	13	141	168	90	40	88	109	30	—	184	—
φ40	□65	Rc3/8	φ11	69	38	40	13	141	168	90	46	95	118	30	35	184	189
φ50	□76	Rc1/2	φ14	85	42	47	18	155	187	98	58	115	145	30	41	203	214
φ63	□90	Rc1/2	φ18	98	46	51	20	163	199	102	65	132	165	35	48	218	231
φ80	□110	Rc3/4	φ18	118	56	62	24	184	228	110	87	155	190	35	51	243	259
φ100	□135	Rc3/4	φ22	150	58	66	28	192	240	116	109	190	230	40	57	260	277
φ125	□165	Rc1	φ26	175	67	76	33	220	273	130	130	224	272	45	57	298	310
φ140	□185	Rc1	φ26	195	69	80	37	230	287	138	145	250	300	50	57	317	324
φ150	□196	Rc1	φ30	210	71	82	39	240	299	146	155	270	320	50	57	329	336
φ160	□210	Rc1	φ33	225	74	84	41	253	314	156	170	285	345	55	57	349	351
φ180	□235	Rc1 1/4	φ33	243	75	88	46	275	335	172	185	315	375	55	—	376	—
φ200	□262	Rc1 1/2	φ36	272	85	99	51	301	368	184	206	355	425	55	—	407	—
φ224	□292	Rc1 1/2	φ42	310	89	106	58	305	379	184	230	395	475	60	—	423	—
φ250	□325	Rc2	φ45	335	106	125	65	346	431	200	250	425	515	65	—	476	—

- The tolerance of B is h8, and that of MM is f8.

### With Boots

Symbol Bore	Rod	φ32	φ40	φ50	φ63	φ80	φ100	φ125	φ140	φ150	φ160	φ180	φ200	φ224	φ250
		WW	Rod B	40	50	63	71	80	100	125	125	140	140	160	180
Rod C	—		50	50	63	71	80	140	125	125	125	125	140	160	180
Rod A	—		63	71	80	100	125	140	160	160	180	—	—	—	—
X	Rod B	45	45	45	55	55	55	65	65	65	65	65	65	80	80
	Rod C	—	45	45	55	55	55	65	65	65	65	65	65	80	80
	Rod A	—	45	55	55	55	65	65	65	65	65	—	—	—	—

CAD/DATA  
70-140H-8/TH8  B is available.

### FC

70H-8	1	FC	Bore	B	B	Stroke	A	B
140H-8	1	FC	Bore	B	B	Stroke	A	B

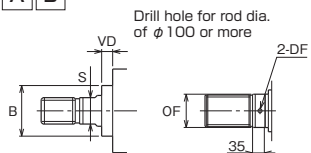

Rod dia.	OF	DF
φ100	φ99.5	φ12
φ112	φ111.5	φ15
φ125	φ124.5	φ15
φ140	φ139.5	φ15

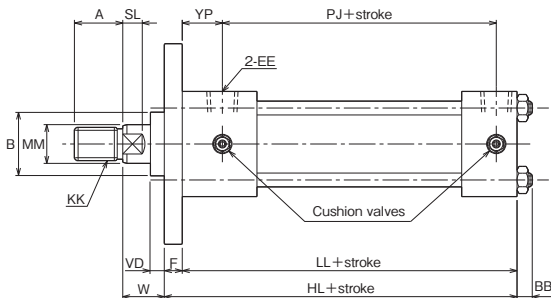
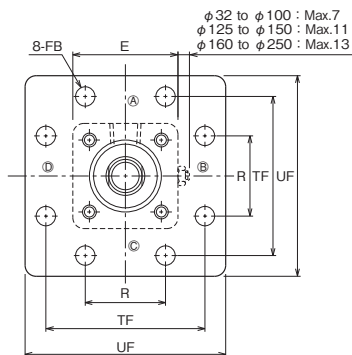

### Double rod type (φ32 to φ250/rod B or C) for loading on both sides

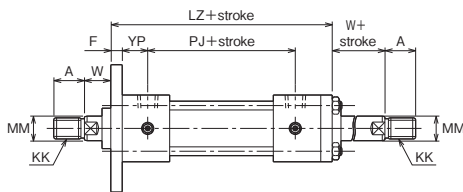

• The Switch Set (φ32 to φ140) is also within the standard stroke range.

- For dimensions not shown in these figures, refer to the SD style (basic style).
- For the mounting of sensors, refer to the dimensional drawings of "Switch Set." All the contents other than "Sensor mounting dimensions" are the same.
- If the port size exceeds 1 inch, it is recommended to order G thread or pipe flange. In such a case, contact us. (Order made)

### With Boots

70-140H-8/TH8  K

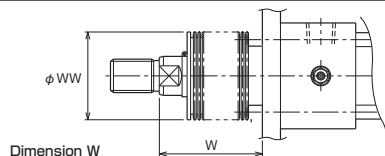

Material	φ	Stroke	W
Nylon tarpaulin Chloroprene	φ32	1/3 stroke+X	1/3 stroke+X
	φ40-φ50	1/3.5 stroke+X	1/3.5 stroke+X
	φ63 to φ100	1/4 stroke+X	1/4 stroke+X
	φ125 to φ200	1/5 stroke+X	1/5 stroke+X
Conex	φ224 to φ250	1/6 stroke+X	1/6 stroke+X
	φ32	1/2 stroke+X	1/2 stroke+X
	φ40-φ50	1/2.5 stroke+X	1/2.5 stroke+X
	φ63 to φ100	1/3 stroke+X	1/3 stroke+X
	φ125-φ140	1/3.5 stroke+X	1/3.5 stroke+X
	φ150 to φ200	1/4 stroke+X	1/4 stroke+X
	φ224-φ250	1/4.5 stroke+X	1/4.5 stroke+X

	Standard	Semi-standard	
Material	Nylon tarpaulin	Chloroprene	Conex
Heat proof	80°C	130°C	200°C

#### Notes

- Remember that the heat proof field in the table above shows the allowable temperatures for the boots, not for the cylinder.
- Conex is the registered trademark of Teijin Limited.
- If the calculated value has a fractional part, round it up.
- The boots have been mounted at our factory prior to delivery.

### Dimensional Table

Symbol Bore	Rod B							Rod C						
	A	B	KK	MM	S	SL	VD	A	B	KK	MM	S	SL	VD
φ32	25	φ34	M16×1.5	φ18	14	10	10	—	—	—	—	—	—	—
φ40	30	φ40	M20×1.5	φ22.4	19	11	10	25	φ36	M16×1.5	φ18	14	10	10
φ50	35	φ46	M24×1.5	φ28	24	14	10	30	φ40	M20×1.5	φ22.4	19	11	10
φ63	45	φ55	M30×1.5	φ35.5	30	16	10	35	φ46	M24×1.5	φ28	24	14	10
φ80	60	φ65	M39×1.5	φ45	41	20	10	45	φ55	M30×1.5	φ35.5	30	16	9
φ100	75	φ80	M48×1.5	φ56	50	23	10	60	φ65	M39×1.5	φ45	41	20	10
φ125	95	φ95	M64×2	φ71	65	27	10	75	φ80	M48×1.5	φ56	50	23	10
φ140	110	φ105	M72×2	φ80	75	31	10	80	φ85	M56×2	φ63	55	24	10
φ150	115	φ110	M76×2	φ85	80	33	10	85	φ90	M60×2	φ67	60	30	10
φ160	120	φ115	M80×2	φ90	85	33	10	95	φ95	M64×2	φ71	65	27	10
φ180	140	φ125	M95×2	φ100	—	Drill hole	10	110	φ105	M72×2	φ80	75	31	10
φ200	150	φ140	M100×2	φ112	—	Drill hole	10	120	φ115	M80×2	φ90	85	33	10
φ224	180	φ150	M120×2	φ125	—	Drill hole	10	140	φ125	M95×2	φ100	—	Drill hole	10
φ250	195	φ170	M130×2	φ140	—	Drill hole	10	150	φ140	M100×2	φ112	—	Drill hole	10

Symbol Bore	BB	E	EE	F	FB	HL	LL	LZ	PJ	R	TF	UF	W	YP
φ32	11	□58	Rc3/8	11	φ11	141	130	166	90	40	88	109	30	27
φ40	11	□65	Rc3/8	11	φ11	141	130	166	90	46	95	118	30	27
φ50	11	□76	Rc1/2	13	φ14	155	142	182	98	58	115	145	30	29
φ63	13	□90	Rc1/2	15	φ18	163	148	194	102	65	132	165	35	31
φ80	16	□110	Rc3/4	18	φ18	184	166	222	110	87	155	190	35	38
φ100	18	□135	Rc3/4	20	φ22	192	172	232	116	109	190	230	40	38
φ125	21	□165	Rc1	24	φ26	220	196	264	130	130	224	272	45	43
φ140	22	□185	Rc1	26	φ26	230	204	276	138	145	250	300	50	43
φ150	25	□196	Rc1	28	φ30	240	212	288	146	155	270	320	50	43
φ160	25	□210	Rc1	31	φ33	253	222	304	156	170	285	345	55	43
φ180	27	□235	Rc1 1/4	33	φ33	275	242	322	172	185	315	375	55	42
φ200	29	□262	Rc1 1/2	37	φ36	301	264	354	184	206	355	425	55	48
φ224	34	□292	Rc1 1/2	41	φ42	305	264	362	184	230	395	475	60	48
φ250	37	□325	Rc2	46	φ45	346	300	412	200	250	425	515	65	60

• The tolerance of B is h8, and that of MM is f8.

### With Boots

Symbol Bore	Rod	φ32	φ40	φ50	φ63	φ80	φ100	φ125	φ140	φ150	φ160	φ180	φ200	φ224	φ250
		WW	Rod B	40	50	63	71	80	100	125	125	140	140	160	180
X	Rod C	—	50	50	63	71	80	100	125	125	125	125	140	160	180
	Rod B	45	45	45	55	55	55	65	65	65	65	65	65	80	80
	Rod C	—	45	45	55	55	55	65	65	65	65	65	65	80	80

• The boots have been mounted at our factory prior to delivery.

CAD/DATA is available.

70-140H-8/TH8 [Bore] B

### FD

70H-8	1	FD	Bore	B	B	Stroke	A	B
140H-8	1	FD	Bore	B	B	Stroke	A	B

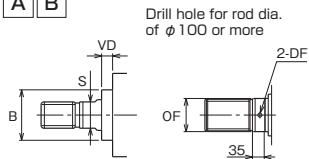

Rod dia.	OF	DF
φ100	φ99.5	φ12
φ112	φ111.5	φ15
φ125	φ124.5	φ15
φ140	φ139.5	φ15

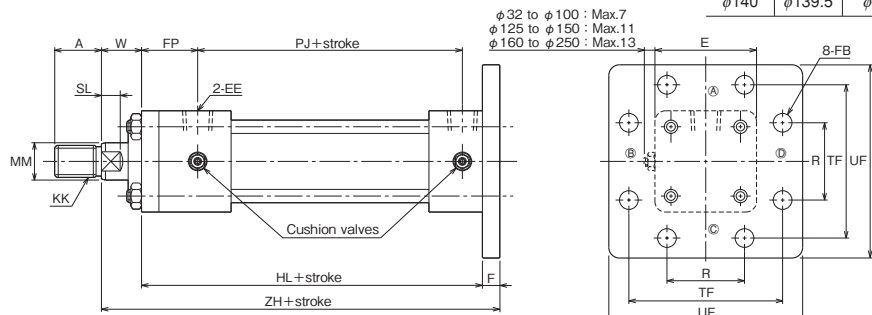

### Double rod type (φ32 to φ250/rod B or C) for loading on both sides

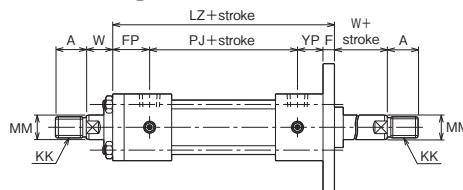

- For dimensions not shown in these figures, refer to the SD style (basic style).
- For the mounting of sensors, refer to the dimensional drawings of "Switch Set." All the contents other than "Sensor mounting dimensions" are the same.
- If the port size exceeds 1 inch, it is recommended to order G thread or pipe flange. In such a case, contact us. (Order made)

The Switch Set (φ32 to φ140) is also within the standard stroke range.

### With Boots

70-140H-8/TH8 [Bore] K

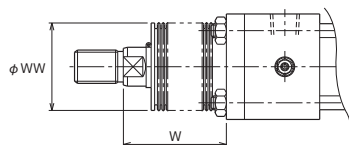

	Standard	Semi-standard	
Material	Nylon tarpaulin	Chloroprene	Conex
Heat proof	80°C	130°C	200°C

#### Notes

- Remember that the heat proof field in the table above shows the allowable temperatures for the boots, not for the cylinder.
- Conex is the registered trademark of Teijin Limited.
- If the calculated value has a fractional part, round it up.
- The boots have been mounted at our factory prior to delivery.

#### Rod A

Nylon tarpaulin	φ40	1/3.5 stroke+X
Chloroprene	φ50 to φ80	1/4 stroke+X
	φ100 to φ160	1/5 stroke+X
Conex	φ40	1/2.5 stroke+X
	φ50 to φ80	1/3 stroke+X
	φ100	1/3.5 stroke+X
	φ125 to φ200	1/4 stroke+X
	φ224 · φ250	1/4.5 stroke+X

#### Dimension W Rod B/C

Nylon tarpaulin	φ32	1/3 stroke+X
	φ40 · φ50	1/3.5 stroke+X
	φ63 to φ100	1/4 stroke+X
	φ125 to φ200	1/5 stroke+X
	φ224 to φ250	1/6 stroke+X
Conex	φ32	1/2 stroke+X
	φ40 · φ50	1/2.5 stroke+X
	φ63 to φ100	1/3 stroke+X
	φ125 · φ140	1/3.5 stroke+X
	φ150 to φ200	1/4 stroke+X
	φ224 · φ250	1/4.5 stroke+X

### Dimensional Table

Symbol Bore	Rod B							Rod C							Rod A							
	A	B	KK	MM	S	SL	VD	A	B	KK	MM	S	SL	VD	A	B	KK	MM	S	SL	VD	
φ32	25	φ34	M16×1.5	φ18	14	10	10	—	—	—	—	—	—	—	—	—	—	—	—	—	—	—
φ40	30	φ40	M20×1.5	φ22.4	19	11	10	25	φ36	M16×1.5	φ18	14	10	10	35	φ43	M24×1.5	φ28	24	14	17	—
φ50	35	φ46	M24×1.5	φ28	24	14	10	30	φ40	M20×1.5	φ22.4	19	11	10	45	φ50	M30×1.5	φ35.5	30	16	17	—
φ63	45	φ55	M30×1.5	φ35.5	30	16	10	35	φ46	M24×1.5	φ28	24	14	10	60	φ65	M39×1.5	φ45	41	20	19	—
φ80	60	φ65	M39×1.5	φ45	41	20	10	45	φ55	M30×1.5	φ35.5	30	16	9	75	φ80	M48×1.5	φ56	50	23	20	—
φ100	75	φ80	M48×1.5	φ56	50	23	10	60	φ65	M39×1.5	φ45	41	20	10	95	φ95	M64×2	φ71	65	27	23	—
φ125	95	φ95	M64×2	φ71	65	27	10	75	φ80	M48×1.5	φ56	50	23	10	120	φ115	M80×2	φ90	85	33	17	—
φ140	110	φ105	M72×2	φ80	75	31	10	80	φ85	M56×2	φ63	55	24	10	140	φ125	M95×2	φ100	—	—	—	17
φ150	115	φ110	M76×2	φ85	80	33	10	85	φ90	M60×2	φ67	60	30	10	140	φ125	M95×2	φ100	—	—	—	15
φ160	120	φ115	M80×2	φ90	85	33	10	95	φ95	M64×2	φ71	65	27	10	150	φ140	M100×2	φ112	—	—	—	16
φ180	140	φ125	M95×2	φ100	—	—	—	10	110	φ105	M72×2	φ80	75	31	10	—	—	—	—	—	—	—
φ200	150	φ140	M100×2	φ112	—	—	—	10	120	φ115	M80×2	φ90	85	33	10	—	—	—	—	—	—	—
φ224	180	φ150	M120×2	φ125	—	—	—	10	140	φ125	M95×2	φ100	—	—	10	—	—	—	—	—	—	—
φ250	195	φ170	M130×2	φ140	—	—	—	10	150	φ140	M100×2	φ112	—	—	10	—	—	—	—	—	—	—

Symbol Bore	E	EE	F	FB	FP	HL	LZ	PJ	R	TF	UF	W		YP	ZH	
												B · C	A		B · C	A
φ32	□58	Rc3/8	11	φ11	38	141	166	90	40	88	109	30	—	27	182	—
φ40	□65	Rc3/8	11	φ11	38	141	166	90	46	95	118	30	35	27	182	187
φ50	□76	Rc1/2	13	φ14	42	155	182	98	58	115	145	30	41	29	198	209
φ63	□90	Rc1/2	15	φ18	46	163	194	102	65	132	165	35	48	31	213	226
φ80	□110	Rc3/4	18	φ18	56	184	222	110	87	155	190	35	51	38	237	253
φ100	□135	Rc3/4	20	φ22	58	192	232	116	109	190	230	40	57	38	252	269
φ125	□165	Rc1	24	φ26	67	220	264	130	130	224	272	45	57	43	289	301
φ140	□185	Rc1	26	φ26	69	230	276	138	145	250	300	50	57	43	306	313
φ150	□196	Rc1	28	φ30	71	240	288	146	155	270	320	50	57	43	318	325
φ160	□210	Rc1	31	φ33	74	253	304	156	170	285	345	55	57	43	339	341
φ180	□235	Rc1 1/4	33	φ33	75	275	322	172	185	315	375	55	—	42	363	—
φ200	□262	Rc1 1/2	37	φ36	85	301	354	184	206	355	425	55	—	48	393	—
φ224	□292	Rc1 1/2	41	φ42	89	305	362	184	230	395	475	60	—	48	406	—
φ250	□325	Rc2	46	φ45	106	346	412	200	250	425	515	65	—	60	457	—

The tolerance of B is h8, and that of MM is f8.

### With Boots

Symbol Bore		φ32	φ40	φ50	φ63	φ80	φ100	φ125	φ140	φ150	φ160	φ180	φ200	φ224	φ250
		WW	Rod B	40	50	63	71	80	100	125	125	140	140	160	180
	Rod C	—	50	50	63	71	80	100	125	125	125	125	140	160	180
	Rod A	—	63	71	80	100	125	140	160	160	180	—	—	—	—
X	Rod B	45	45	45	55	55	55	65	65	65	65	65	65	80	80
	Rod C	—	45	45	55	55	55	65	65	65	65	65	65	80	80
	Rod A	—	45	55	55	55	65	65	65	65	65	—	—	—	—

CAD/DATA is available.

70-140H-8/TH8 Bore A. C

### CA

70H-8	1	CA	Bore	B	B	Stroke	A	B
140H-8	1	CA	Bore	B	B	Stroke	A	B

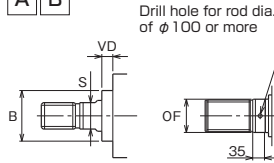

Rod dia.	OF	DF
φ100	φ99.5	φ12
φ112	φ111.5	φ15
φ125	φ124.5	φ15
φ140	φ139.5	φ15

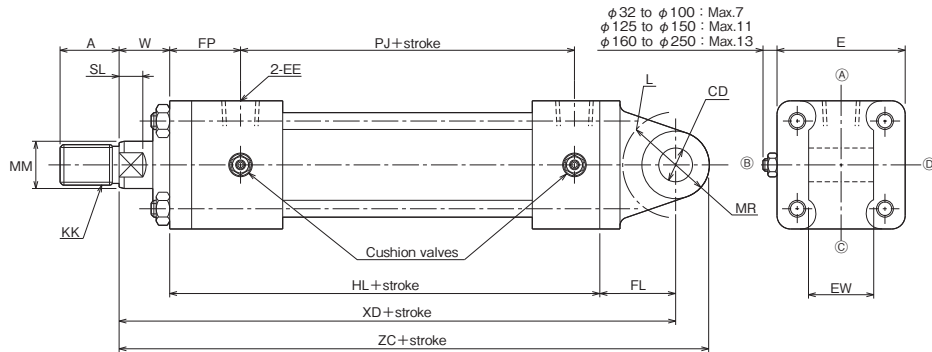

- For dimensions not shown in these figures, refer to the SD style (basic style).
- For the mounting of sensors, refer to the dimensional drawings of "Switch Set." All the contents other than "Sensor mounting dimensions" are the same.
- For the cylinders with a bore of 180 mm or more, the CA accessory is provided with a gray cast iron bush.
- The CA accessory for cylinders with a bore of 180 mm or more is made of rolled steel for general structure (welding type) and provided with a gray cast iron bush.
- If the port size exceeds 1 inch, it is recommended to order G thread or pipe flange. In such a case, contact us. (Order made)

### With Boots

70-140H-8/TH8 Bore K

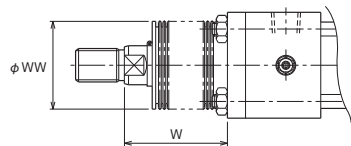

	Standard	Semi-standard	
Material	Nylon tarpaulin	Chloroprene	Conex
Heat proof	80°C	130°C	200°C

#### Notes

- Remember that the heat proof field in the table above shows the allowable temperatures for the boots, not for the cylinder.
- Conex is the registered trademark of Teijin Limited.
- The boots have been mounted at our factory prior to delivery.

#### Rod A

Nylon tarpaulin	φ40	1/3.5 stroke+X
Chloroprene	φ50 to φ80	1/4 stroke+X
	φ100 to φ160	1/5 stroke+X
Conex	φ40	1/2.5 stroke+X
	φ50 to φ80	1/3 stroke+X
	φ100	1/3.5 stroke+X
	φ125 to φ160	1/4 stroke+X

#### Dimension W

Nylon tarpaulin	φ32	1/3 stroke+X
Chloroprene	φ40·φ50	1/3.5 stroke+X
	φ63 to φ100	1/4 stroke+X
	φ125 to φ200	1/5 stroke+X
	φ224 to φ250	1/6 stroke+X
Conex	φ32	1/2 stroke+X
	φ40·φ50	1/2.5 stroke+X
	φ63 to φ100	1/3 stroke+X
	φ125 to φ140	1/3.5 stroke+X
	φ150 to φ200	1/4 stroke+X
	φ224·φ250	1/4.5 stroke+X

- If the calculated value has a fractional part, round it up.

### Dimensional Table

Symbol Bore	Rod B							Rod C							Rod A							
	A	B	KK	MM	S	SL	VD	A	B	KK	MM	S	SL	VD	A	B	KK	MM	S	SL	VD	
φ32	25	φ34	M16×1.5	φ18	14	10	10	—	—	—	—	—	—	—	—	—	—	—	—	—	—	—
φ40	30	φ40	M20×1.5	φ22.4	19	11	10	25	φ36	M16×1.5	φ18	14	10	10	35	φ43	M24×1.5	φ28	24	14	17	—
φ50	35	φ46	M24×1.5	φ28	24	14	10	30	φ40	M20×1.5	φ22.4	19	11	10	45	φ50	M30×1.5	φ35.5	30	16	17	—
φ63	45	φ55	M30×1.5	φ35.5	30	16	10	35	φ46	M24×1.5	φ28	24	14	10	60	φ65	M39×1.5	φ45	41	20	19	—
φ80	60	φ65	M39×1.5	φ45	41	20	10	45	φ55	M30×1.5	φ35.5	30	16	9	75	φ80	M48×1.5	φ56	50	23	20	—
φ100	75	φ80	M48×1.5	φ56	50	23	10	60	φ65	M39×1.5	φ45	41	20	10	95	φ95	M64×2	φ71	65	27	23	—
φ125	95	φ95	M64×2	φ71	65	27	10	75	φ80	M48×1.5	φ56	50	23	10	120	φ115	M80×2	φ90	85	33	17	—
φ140	110	φ105	M72×2	φ80	75	31	10	80	φ85	M56×2	φ63	55	24	10	140	φ125	M95×2	φ100	—	—	—	17
φ150	115	φ110	M76×2	φ85	80	33	10	85	φ90	M60×2	φ67	60	30	10	140	φ125	M95×2	φ100	—	—	—	15
φ160	120	φ115	M80×2	φ90	85	33	10	95	φ95	M64×2	φ71	65	27	10	150	φ140	M100×2	φ112	—	—	—	16
φ180	140	φ125	M95×2	φ100	—	—	10	110	φ105	M72×2	φ80	75	31	10	—	—	—	—	—	—	—	—
φ200	150	φ140	M100×2	φ112	—	—	10	120	φ115	M80×2	φ90	85	33	10	—	—	—	—	—	—	—	—
φ224	180	φ150	M120×2	φ125	—	—	10	140	φ125	M95×2	φ100	—	—	10	—	—	—	—	—	—	—	—
φ250	195	φ170	M130×2	φ140	—	—	10	150	φ140	M100×2	φ112	—	—	10	—	—	—	—	—	—	—	—

Symbol Bore	CD	E	EE	EW	FL	FP	HL	L	MR	PJ	W		XD		ZC	
											B·C	A	B·C	A	B·C	A
φ32	φ16H9	□58	Rc3/8	25 <sup>-0.1</sup> <sub>-0.4</sub>	38	38	141	R20	R16	90	30	—	209	—	225	—
φ40	φ16H9	□65	Rc3/8	25 <sup>-0.1</sup> <sub>-0.4</sub>	38	38	141	R20	R16	90	30	35	209	214	225	230
φ50	φ20H9	□76	Rc1/2	31.5 <sup>-0.1</sup> <sub>-0.4</sub>	45	42	155	R25	R20	98	30	41	230	241	250	261
φ63	φ31.5H9	□90	Rc1/2	40 <sup>-0.1</sup> <sub>-0.4</sub>	63	46	163	R46	R31.5	102	35	48	261	274	292.5	305.5
φ80	φ31.5H9	□110	Rc3/4	40 <sup>-0.1</sup> <sub>-0.4</sub>	72	56	184	R52	R31.5	110	35	51	291	307	322.5	338.5
φ100	φ40H9	□135	Rc3/4	50 <sup>-0.1</sup> <sub>-0.4</sub>	84	58	192	R62	R40	116	40	57	316	333	356	373
φ125	φ50H9	□165	Rc1	63 <sup>-0.1</sup> <sub>-0.4</sub>	100	67	220	R73	R50	130	45	57	365	377	415	427
φ140	φ63H9	□185	Rc1	80 <sup>-0.1</sup> <sub>-0.6</sub>	120	69	230	R91	R63	138	50	57	400	407	463	470
φ150	φ63H9	□196	Rc1	80 <sup>-0.1</sup> <sub>-0.6</sub>	122	71	240	R91	R63	146	50	57	412	419	475	482
φ160	φ71H9	□210	Rc1	80 <sup>-0.1</sup> <sub>-0.6</sub>	137	74	253	R103	R71	156	55	57	445	447	516	518
φ180	φ80H9	□235	Rc1 1/4	100 <sup>-0.1</sup> <sub>-0.6</sub>	150	75	275	R100	R80	172	55	—	480	—	560	—
φ200	φ90H9	□262	Rc1 1/2	125 <sup>-0.1</sup> <sub>-0.6</sub>	170	85	301	R115	R90	184	55	—	526	—	616	—
φ224	φ100H9	□292	Rc1 1/2	125 <sup>-0.1</sup> <sub>-0.6</sub>	185	89	305	R125	R100	184	60	—	550	—	650	—
φ250	φ100H9	□325	Rc2	125 <sup>-0.1</sup> <sub>-0.6</sub>	185	106	346	R125	R100	200	65	—	596	—	696	—

- The tolerance of B is h8, and that of MM is f8.

### With Boots

Symbol Bore	Rod	φ32	φ40	φ50	φ63	φ80	φ100	φ125	φ140	φ150	φ160	φ180	φ200	φ224	φ250
		WW	Rod B	40	50	63	71	80	100	125	125	140	140	160	180
X	Rod C	—	50	50	63	71	80	100	125	125	125	125	140	160	180
	Rod A	—	63	71	80	100	125	140	160	160	180	—	—	—	—
	Rod B	45	45	45	55	55	55	65	65	65	65	65	65	80	80
X	Rod C	—	45	45	55	55	55	65	65	65	65	65	65	80	80
	Rod A	—	45	55	55	55	65	65	65	65	65	—	—	—	—
	Rod B	—	45	55	55	55	65	65	65	65	65	—	—	—	—

CAD/DATA  
70-140H-8/TH8 BoreA. C is available.

### CS

70H-8	1	CS	<span style="border: 1px solid black; padding: 0 2px;">Bore</span>	<span style="border: 1px solid black; padding: 0 2px;">B</span>	<span style="border: 1px solid black; padding: 0 2px;">B</span>	<span style="border: 1px solid black; padding: 0 2px;">Stroke</span>	-	<span style="border: 1px solid black; padding: 0 2px;">A</span>	<span style="border: 1px solid black; padding: 0 2px;">B</span>
140H-8	1	CS	<span style="border: 1px solid black; padding: 0 2px;">Bore</span>	<span style="border: 1px solid black; padding: 0 2px;">B</span>	<span style="border: 1px solid black; padding: 0 2px;">B</span>	<span style="border: 1px solid black; padding: 0 2px;">Stroke</span>	-	<span style="border: 1px solid black; padding: 0 2px;">A</span>	<span style="border: 1px solid black; padding: 0 2px;">B</span>

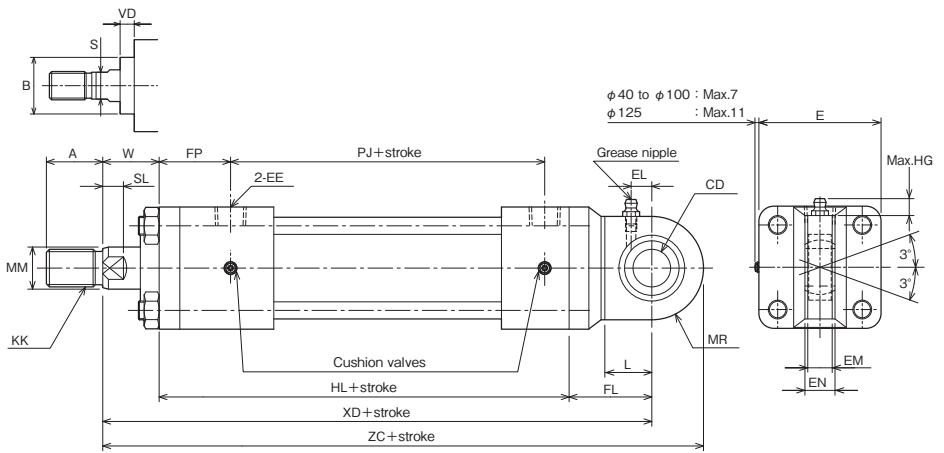

- The spherical bearings are not filled with grease. Lubricate appropriately through the grease nipple.
- The bearing inner diameter and mounting width conform to JIS B8367-2 MP5 type regulation. (Same standard with 160H-1 Series)
- For dimensions not shown in these figures, refer to the SD style (basic style).
- For the mounting of sensors, refer to the dimensional drawings of "Switch Set." All the contents other than "Sensor mounting dimensions" are the same.

### With Boots

70-140H-8/TH8 BoreK

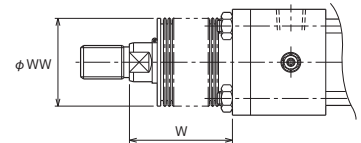

Dimension W	Rod B/C	Material	Stroke
Nylon tarpaulin	φ40-φ50	Chloroprene	1/3.5 stroke+X
			1/4 stroke+X
			1/5 stroke+X
Conex	φ40-φ50	Chloroprene	1/2.5 stroke+X
			1/3 stroke+X
			1/3.5 stroke+X

	Standard	Semi-standard	
Material	Nylon tarpaulin	Chloroprene	Conex
Heat proof	80°C	130°C	200°C

- Notes
- Remember that the heat proof field in the table above shows the allowable temperatures for the boots, not for the cylinder.
  - Conex is the registered trademark of Teijin Limited.
  - The boots have been mounted at our factory prior to delivery.

Rod A	Material	Stroke
Nylon tarpaulin	Chloroprene	1/3.5 stroke+X
		1/4 stroke+X
		1/5 stroke+X
Conex	Chloroprene	1/2.5 stroke+X
		1/3 stroke+X
		1/3.5 stroke+X
		1/4 stroke+X

• If the calculated value has a fractional part, round it up.

### Dimensional Table

Symbol Bore	Rod B							Rod C							Rod A						
	A	B	KK	MM	S	SL	VD	A	B	KK	MM	S	SL	VD	A	B	KK	MM	S	SL	VD
φ40	30	φ40	M20×1.5	φ22.4	19	11	10	25	φ36	M16×1.5	φ18	14	10	10	35	φ43	M24×1.5	φ28	24	14	17
φ50	35	φ46	M24×1.5	φ28	24	14	10	30	φ40	M20×1.5	φ22.4	19	11	10	45	φ50	M30×1.5	φ35.5	30	16	17
φ63	45	φ55	M30×1.5	φ35.5	30	16	10	35	φ46	M24×1.5	φ28	24	14	10	60	φ65	M39×1.5	φ45	41	20	19
φ80	60	φ65	M39×1.5	φ45	41	20	10	45	φ55	M30×1.5	φ35.5	30	16	9	75	φ80	M48×1.5	φ56	50	23	20
φ100	75	φ80	M48×1.5	φ56	50	23	10	60	φ65	M39×1.5	φ45	41	20	10	95	φ95	M64×2	φ71	65	27	23
φ125	95	φ95	M64×2	φ71	65	27	10	75	φ80	M48×1.5	φ56	50	23	10	120	φ115	M80×2	φ90	85	33	17

Symbol Bore	CD	E	EE	EN	EM	FL	FP	HL	L	MR	PJ	W		XD		ZC		Grease nipple		
												B.C	A	B.C	A	B.C	A	Type	EL	HG
φ40	φ20 <sup>0</sup> <sub>-0.012</sub>	65	Rc3/8	16 <sup>0</sup> <sub>-0.12</sub>	13	44	38	141	25	R27.5	90	30	35	215	220	242.5	247.5	JIS A type MT6×1	11	11
φ50	φ25 <sup>0</sup> <sub>-0.012</sub>	76	Rc1/2	20 <sup>0</sup> <sub>-0.12</sub>	17	53	42	155	31	R32.5	98	30	41	238	249	270.5	281.5	JIS A type MT6×1	14	11
φ63	φ30 <sup>0</sup> <sub>-0.012</sub>	90	Rc1/2	22 <sup>0</sup> <sub>-0.12</sub>	19	64	46	163	38	R40	102	35	48	262	275	302	315	JIS A type Rc1/8	15	15
φ80	φ40 <sup>0</sup> <sub>-0.012</sub>	110	Rc3/4	28 <sup>0</sup> <sub>-0.12</sub>	23	81	56	184	48	R50	110	35	51	300	316	350	366	JIS A type Rc1/8	20	15
φ100	φ50 <sup>0</sup> <sub>-0.012</sub>	135	Rc3/4	35 <sup>0</sup> <sub>-0.12</sub>	30	96	58	192	58	R60	116	40	57	328	345	388	405	JIS A type Rc1/8	24	15
φ125	φ60 <sup>0</sup> <sub>-0.015</sub>	165	Rc1	44 <sup>0</sup> <sub>-0.15</sub>	38	117	67	220	72	R75	130	45	57	382	394	457	469	JIS A type Rc1/8	28	15

• The tolerance of B is h8, and that of MM is f8.

### With Boots

Bore	Symbol	φ40	φ50	φ63	φ80	φ100	φ125
		WW	Rod B	50	63	71	80
Rod C	50		50	63	71	80	100
Rod A	63		71	80	100	125	140
X	Rod B	45	45	55	55	55	65
	Rod C	45	45	55	55	55	65
	Rod A	45	55	55	55	65	65

CAD/DATA is available.

70-140H-8/TH8 Bore A. C

### CB

70H-8	1	CB	Bore	B	B	Stroke	A	B
140H-8	1	CB	Bore	B	B	Stroke	A	B

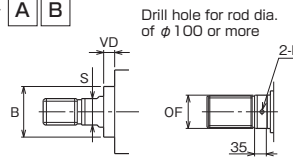

Rod dia.	OF	DF
φ100	φ99.5	φ12
φ112	φ111.5	φ15
φ125	φ124.5	φ15
φ140	φ139.5	φ15

#### • Bore φ32 to φ80

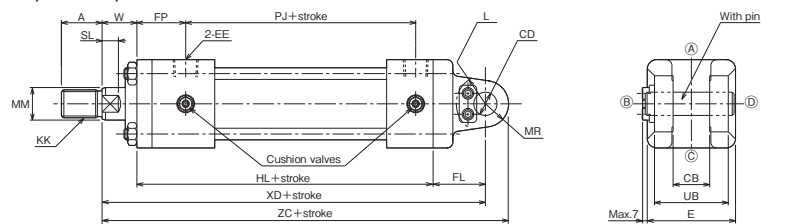

#### • Bore φ100 to φ250

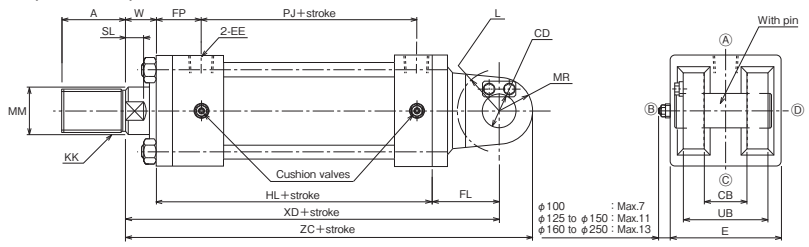

- For dimensions not shown in these figures, refer to the SD style (basic style).
- For the mounting of sensors, refer to the dimensional drawings of "Switch Set." All the contents other than "Sensor mounting dimensions" are the same.
- Material of CB accessory for cylinders with bores from 32 to 160 mm: Nodular graphite cast iron (basic style).
- Material of CB accessory for cylinders with a bore of 180 mm or more: Rolled steel for general structure
- If the port size exceeds 1 inch, it is recommended to order G thread or pipe flange. In such a case, contact us. (Order made)

#### With Boots

70-140H-8/TH8 K

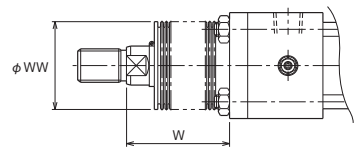

Material	Bore Range	Stroke
Nylon tarpaulin Chloroprene	φ32	1/3 stroke+X
	φ40-φ50	1/3.5 stroke+X
	φ63 to φ100	1/4 stroke+X
	φ125 to φ200	1/5 stroke+X
	φ224 to φ250	1/6 stroke+X
Conex	φ32	1/2 stroke+X
	φ40-φ50	1/2.5 stroke+X
	φ63 to φ100	1/3 stroke+X
	φ125-φ140	1/3.5 stroke+X
	φ150 to φ200	1/4 stroke+X
	φ224-φ250	1/4.5 stroke+X

• If the calculated value has a fractional part, round it up.

	Standard	Semi-standard	
Material	Nylon tarpaulin	Chloroprene	Conex
Heat proof	80°C	130°C	200°C

- Notes)
- Remember that the heat proof field in the table above shows the allowable temperatures for the boots, not for the cylinder.
  - Conex is the registered trademark of Teijin Limited.
  - The boots have been mounted at our factory prior to delivery.
- | Rod A                          | Bore Range   | Stroke         |
|--------------------------------|--------------|----------------|
| Nylon tarpaulin<br>Chloroprene | φ40          | 1/3.5 stroke+X |
|                                | φ50 to φ80   | 1/4 stroke+X   |
|                                | φ100 to φ160 | 1/5 stroke+X   |
| Conex                          | φ40          | 1/2.5 stroke+X |
|                                | φ50 to φ80   | 1/3 stroke+X   |
|                                | φ100         | 1/3.5 stroke+X |
|                                | φ125 to φ160 | 1/4 stroke+X   |

### Dimensional Table

Symbol Bore	Rod B							Rod C							Rod A							
	A	B	KK	MM	S	SL	VD	A	B	KK	MM	S	SL	VD	A	B	KK	MM	S	SL	VD	
φ32	25	φ34	M16×1.5	φ18	14	10	10	—	—	—	—	—	—	—	—	—	—	—	—	—	—	—
φ40	30	φ40	M20×1.5	φ22.4	19	11	10	25	φ36	M16×1.5	φ18	14	10	10	35	φ43	M24×1.5	φ28	24	14	17	—
φ50	35	φ46	M24×1.5	φ28	24	14	10	30	φ40	M20×1.5	φ22.4	19	11	10	45	φ50	M30×1.5	φ35.5	30	16	17	—
φ63	45	φ55	M30×1.5	φ35.5	30	16	10	35	φ46	M24×1.5	φ28	24	14	10	60	φ65	M39×1.5	φ45	41	20	19	—
φ80	60	φ65	M39×1.5	φ45	41	20	10	45	φ55	M30×1.5	φ35.5	30	16	9	75	φ80	M48×1.5	φ56	50	23	20	—
φ100	75	φ80	M48×1.5	φ56	50	23	10	60	φ65	M39×1.5	φ45	41	20	10	95	φ95	M64×2	φ71	65	27	23	—
φ125	95	φ95	M64×2	φ71	65	27	10	75	φ80	M48×1.5	φ56	50	23	10	120	φ115	M80×2	φ90	85	33	17	—
φ140	110	φ105	M72×2	φ80	75	31	10	80	φ85	M56×2	φ63	55	24	10	140	φ125	M95×2	φ100	—	—	17	—
φ150	115	φ110	M76×2	φ85	80	33	10	85	φ90	M60×2	φ67	60	30	10	140	φ125	M95×2	φ100	—	—	15	—
φ160	120	φ115	M80×2	φ90	85	33	10	95	φ95	M64×2	φ71	65	27	10	150	φ140	M100×2	φ112	—	—	16	—
φ180	140	φ125	M95×2	φ100	—	—	10	110	φ105	M72×2	φ80	75	31	10	—	—	—	—	—	—	—	—
φ200	150	φ140	M100×2	φ112	—	—	10	120	φ115	M80×2	φ90	85	33	10	—	—	—	—	—	—	—	—
φ224	180	φ150	M120×2	φ125	—	—	10	140	φ125	M95×2	φ100	—	—	10	—	—	—	—	—	—	—	—
φ250	195	φ170	M130×2	φ140	—	—	10	150	φ140	M100×2	φ112	—	—	10	—	—	—	—	—	—	—	—

Symbol Bore	CB	CD	E	EE	FL	FP	HL	L	MR	PJ	UB	W		XD		ZC	
												B·C	A	B·C	A	B·C	A
φ32	25 <sup>+0.4</sup> / <sub>-0.1</sub>	φ16 <sup>H9</sup> / <sub>T8</sub>	□58	Rc3/8	38	38	141	R20	R16	90	50	30	—	209	—	225	—
φ40	25 <sup>+0.4</sup> / <sub>-0.1</sub>	φ16 <sup>H9</sup> / <sub>T8</sub>	□65	Rc3/8	38	38	141	R20	R16	90	50	30	35	209	214	225	230
φ50	31.5 <sup>+0.4</sup> / <sub>-0.1</sub>	φ20 <sup>H9</sup> / <sub>T8</sub>	□76	Rc1/2	45	42	155	R25	R20	98	63.5	30	41	230	241	250	261
φ63	40 <sup>+0.4</sup> / <sub>-0.1</sub>	φ31.5 <sup>H9</sup> / <sub>T8</sub>	□90	Rc1/2	63	46	163	R40	R31.5	102	80	35	48	261	274	292.5	305.5
φ80	40 <sup>+0.4</sup> / <sub>-0.1</sub>	φ31.5 <sup>H9</sup> / <sub>T8</sub>	□110	Rc3/4	72	56	184	R40	R31.5	110	80	35	51	291	307	322.5	338.5
φ100	50 <sup>+0.4</sup> / <sub>-0.1</sub>	φ40 <sup>H9</sup> / <sub>T8</sub>	□135	Rc3/4	84	58	192	R50	R40	116	98	40	57	316	333	356	373
φ125	63 <sup>+0.4</sup> / <sub>-0.1</sub>	φ50 <sup>H9</sup> / <sub>T8</sub>	□165	Rc1	100	67	220	R62	R50	130	126	45	57	365	377	415	427
φ140	80 <sup>+0.6</sup> / <sub>-0.1</sub>	φ63 <sup>H9</sup> / <sub>T8</sub>	□185	Rc1	120	69	230	R79	R63	138	160	50	57	400	407	463	470
φ150	80 <sup>+0.6</sup> / <sub>-0.1</sub>	φ63 <sup>H9</sup> / <sub>T8</sub>	□196	Rc1	122	71	240	R82	R63	146	160	50	57	412	419	475	482
φ160	80 <sup>+0.6</sup> / <sub>-0.1</sub>	φ71 <sup>H9</sup> / <sub>T8</sub>	□210	Rc1	137	74	253	R89	R71	156	160	55	57	445	447	516	518
φ180	100 <sup>+0.6</sup> / <sub>-0.1</sub>	φ80 <sup>H9</sup> / <sub>T8</sub>	□235	Rc1/4	150	75	275	R100	R80	172	200	55	—	480	—	560	—
φ200	125 <sup>+0.6</sup> / <sub>-0.1</sub>	φ90 <sup>H9</sup> / <sub>T8</sub>	□262	Rc1/2	170	85	301	R115	R90	184	251	55	—	526	—	616	—
φ224	125 <sup>+0.6</sup> / <sub>-0.1</sub>	φ100 <sup>H9</sup> / <sub>T8</sub>	□292	Rc1/2	185	89	305	R125	R100	184	251	60	—	550	—	650	—
φ250	125 <sup>+0.6</sup> / <sub>-0.1</sub>	φ100 <sup>H9</sup> / <sub>T8</sub>	□325	Rc2	185	106	346	R125	R100	200	251	65	—	596	—	696	—

• The tolerance of B is h8, and that of MM is f8.

#### With Boots

Symbol Bore	Rod	φ32	φ40	φ50	φ63	φ80	φ100	φ125	φ140	φ150	φ160	φ180	φ200	φ224	φ250
		WW	Rod B	40	50	63	71	80	100	125	125	140	140	160	180
X	Rod C	—	50	50	63	71	80	100	125	125	125	125	140	160	180
	Rod A	—	63	71	80	100	125	140	160	160	180	—	—	—	—
X	Rod B	45	45	45	55	55	55	65	65	65	65	65	65	80	80
	Rod C	—	45	45	55	55	55	65	65	65	65	65	65	80	80
X	Rod A	—	45	55	55	55	65	65	65	65	65	—	—	—	—

CAD/DATA is available.

70-140H-8/TH8 [Bore] A. C

### TA

70H-8	1	TA	Bore	B	B	Stroke	A	C
140H-8	1	TA	Bore	B	B	Stroke	A	C

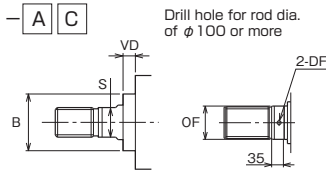

Rod dia.	OF	DF
φ100	φ99.5	φ12
φ112	φ111.5	φ15
φ125	φ124.5	φ15
φ140	φ139.5	φ15

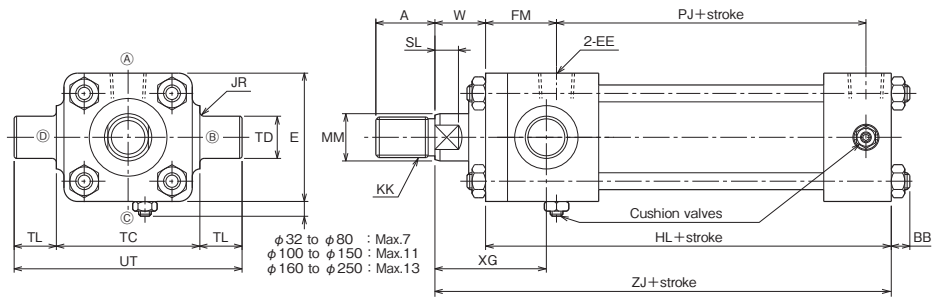

- For dimensions not shown in these figures, refer to the SD style (basic style).
- For the mounting of sensors, refer to the dimensional drawings of "Switch Set." All the contents other than "Sensor mounting dimensions" are the same.
- The cushion valve and air vent of the TA style are positioned on © for structural reasons (rod cover side).
- If the port size exceeds 1 inch, it is recommended to order G thread or pipe flange. In such a case, contact us. (Order made)

### Double rod type (rod B or C) for loading on both sides

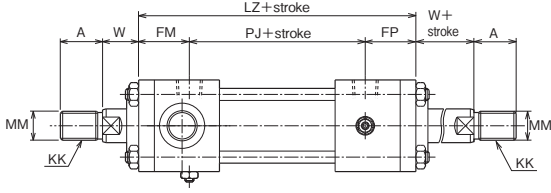

- The Switch Set (φ32 to φ140) is also within the standard stroke range.

### With Boots

70-140H-8/TH8 [Bore] K

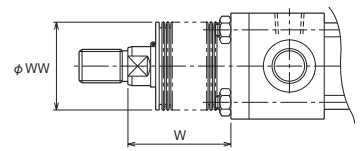

	Standard	Semi-standard	
Material	Nylon tarpaulin	Chloroprene	Conex
Heat proof	80°C	130°C	200°C

- Notes)
- Remember that the heat proof field in the table above shows the allowable temperatures for the boots, not for the cylinder.
  - Conex is the registered trademark of Teijin Limited.
  - The boots have been mounted at our factory prior to delivery.

Dimension W	Rod B/C	Stroke
Nylon tarpaulin	φ32	1/3 stroke+X
Chloroprene	φ40-φ50	1/3.5 stroke+X
	φ63 to φ100	1/4 stroke+X
	φ125 to φ200	1/5 stroke+X
	φ224 to φ250	1/6 stroke+X
Conex	φ32	1/2 stroke+X
	φ40-φ50	1/2.5 stroke+X
	φ63 to φ100	1/3 stroke+X
	φ125 to φ140	1/3.5 stroke+X
	φ150 to φ200	1/4 stroke+X
	φ224-φ250	1/4.5 stroke+X

- If the calculated value has a fractional part, round it up.

Rod A	Material	Stroke
Nylon tarpaulin	φ40	1/3.5 stroke+X
Chloroprene	φ50 to φ80	1/4 stroke+X
	φ100 to φ160	1/5 stroke+X
Conex	φ40	1/2.5 stroke+X
	φ50 to φ80	1/3 stroke+X
	φ100	1/3.5 stroke+X
	φ125 to φ160	1/4 stroke+X

### Dimensional Table

Symbol Bore	Rod B							Rod C							Rod A							
	A	B	KK	MM	S	SL	VD	A	B	KK	MM	S	SL	VD	A	B	KK	MM	S	SL	VD	
φ32	25	φ34	M16×1.5	φ18	14	10	10	—	—	—	—	—	—	—	—	—	—	—	—	—	—	—
φ40	30	φ40	M20×1.5	φ22.4	19	11	10	25	φ36	M16×1.5	φ18	14	10	10	35	φ43	M24×1.5	φ28	24	14	17	—
φ50	35	φ46	M24×1.5	φ28	24	14	10	30	φ40	M20×1.5	φ22.4	19	11	10	45	φ50	M30×1.5	φ35.5	30	16	17	—
φ63	45	φ55	M30×1.5	φ35.5	30	16	10	35	φ46	M24×1.5	φ28	24	14	10	60	φ65	M39×1.5	φ45	41	20	19	—
φ80	60	φ65	M39×1.5	φ45	41	20	10	45	φ55	M30×1.5	φ35.5	30	16	9	75	φ80	M48×1.5	φ56	50	23	20	—
φ100	75	φ80	M48×1.5	φ56	50	23	10	60	φ65	M39×1.5	φ45	41	20	10	95	φ95	M64×2	φ71	65	27	23	—
φ125	95	φ95	M64×2	φ71	65	27	10	75	φ80	M48×1.5	φ56	50	23	10	120	φ115	M80×2	φ90	85	33	17	—
φ140	110	φ105	M72×2	φ80	75	31	10	80	φ85	M56×2	φ63	55	24	10	140	φ125	M95×2	φ100	—	—	—	Drill hole
φ150	115	φ110	M76×2	φ85	80	33	10	85	φ90	M60×2	φ67	60	30	10	140	φ125	M95×2	φ100	—	—	—	Drill hole
φ160	120	φ115	M80×2	φ90	85	33	10	95	φ95	M64×2	φ71	65	27	10	150	φ140	M100×2	φ112	—	—	—	Drill hole
φ180	140	φ125	M95×2	φ100	—	—	10	110	φ105	M72×2	φ80	75	31	10	—	—	—	—	—	—	—	—
φ200	150	φ140	M100×2	φ112	—	—	10	120	φ115	M80×2	φ90	85	33	10	—	—	—	—	—	—	—	—
φ224	180	φ150	M120×2	φ125	—	—	10	140	φ125	M95×2	φ100	—	—	10	—	—	—	—	—	—	—	—
φ250	195	φ170	M130×2	φ140	—	—	10	150	φ140	M100×2	φ112	—	—	10	—	—	—	—	—	—	—	—

Symbol Bore	BB	E	EE	FM	FP	HL	JR	LZ	PJ	TC	TD	TL	UT	W		XG		ZJ	
														B·C	A	B·C	A	B·C	A
φ32	11	□58	Rc3/8	38	38	141	R2	166	90	58 <sup>0</sup> <sub>-0.3</sub>	φ20e9	20	98	30	—	62	—	171	—
φ40	11	□65	Rc3/8	38	38	141	R2	166	90	69 <sup>0</sup> <sub>-0.3</sub>	φ20e9	20	109	30	35	62	67	171	176
φ50	11	□76	Rc1/2	42	42	155	R2.5	182	98	85 <sup>0</sup> <sub>-0.35</sub>	φ25e9	25	135	30	41	66	77	185	196
φ63	13	□90	Rc1/2	46	46	163	R2.5	194	102	98 <sup>0</sup> <sub>-0.35</sub>	φ31.5e9	31.5	161	35	48	74	87	198	211
φ80	16	□110	Rc3/4	56	56	184	R2.5	222	110	118 <sup>0</sup> <sub>-0.35</sub>	φ31.5e9	31.5	181	35	51	82	98	219	235
φ100	18	□135	Rc3/4	58	58	192	R3	232	116	145 <sup>0</sup> <sub>-0.4</sub>	φ40e9	40	225	40	57	89	106	232	249
φ125	21	□165	Rc1	67	67	220	R3	264	130	175 <sup>0</sup> <sub>-0.4</sub>	φ50e9	50	275	45	57	103	115	265	277
φ140	22	□185	Rc1	69	69	230	R4	276	138	195 <sup>0</sup> <sub>-0.46</sub>	φ63e9	63	321	50	57	112	119	280	287
φ150	25	□196	Rc1	71	71	240	R4	288	146	206 <sup>0</sup> <sub>-0.46</sub>	φ63e9	63	332	50	57	112	119	290	297
φ160	25	□210	Rc1	74	74	253	R4	304	156	218 <sup>0</sup> <sub>-0.46</sub>	φ71e9	71	360	55	57	126	128	308	310
φ180	27	□235	Rc1 1/4	106	75	306	R4	353	172	243 <sup>0</sup> <sub>-0.46</sub>	φ80e9	80	403	55	—	136	—	361	—
φ200	29	□262	Rc1 1/2	116	85	332	R5	385	184	272 <sup>0</sup> <sub>-0.52</sub>	φ90e9	90	452	55	—	145	—	387	—
φ224	34	□292	Rc1 1/2	129	89	345	R5	402	184	300 <sup>0</sup> <sub>-0.52</sub>	φ100e9	100	500	60	—	160	—	405	—
φ250	37	□325	Rc2	126	106	366	R5	432	200	335 <sup>0</sup> <sub>-0.57</sub>	φ100e9	100	535	65	—	170	—	431	—

- The tolerance of B is h8, and that of MM is f8.

### With Boots

Symbol Bore	Rod	φ32	φ40	φ50	φ63	φ80	φ100	φ125	φ140	φ150	φ160	φ180	φ200	φ224	φ250
		WW	Rod B	40	50	63	71	80	100	125	125	140	140	160	180
	Rod C	—	50	50	63	71	80	100	125	125	125	125	140	160	180
	Rod A	—	63	71	80	100	125	140	160	160	180	—	—	—	—
X	Rod B	45	45	45	55	55	55	65	65	65	65	65	65	80	80
	Rod C	—	45	45	55	55	55	65	65	65	65	65	65	80	80
	Rod A	—	45	55	55	55	65	65	65	65	65	65	—	—	—

CAD/DATA  is available.

70-140H-8/TH8  A. C 

### TC

70H-8	1	TC	Bore	B	B	Stroke	A	B
140H-8	1	TC	Bore	B	B	Stroke	A	B

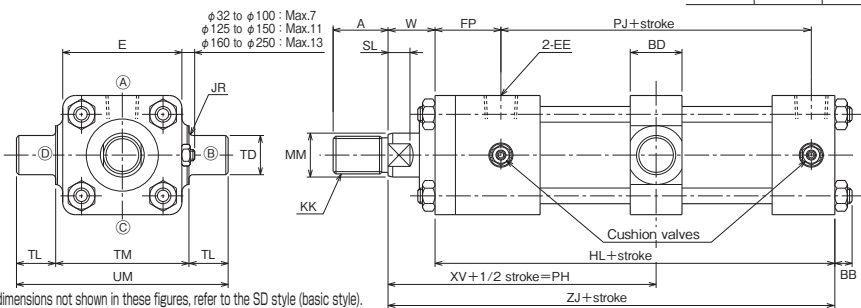
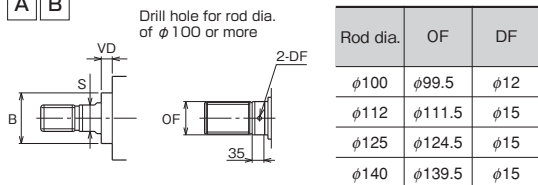

- For dimensions not shown in these figures, refer to the SD style (basic style).
- For the mounting of sensors, refer to the dimensional drawings of "Switch Set." All the contents other than "Sensor mounting dimensions" and "Minimum dimension PH of Switch Set Cylinders" are the same.
- To change the position of TC accessory, specify dimension PH.
- For the cylinders with bores from 140 to 250 mm, the minimum strokes are as shown in the following table.
- If the port size exceeds 1 inch, it is recommended to order G thread or pipe flange. In such a case, contact us. (Order made)

### Double rod type (φ32 to φ250/rod B or C) for loading on both sides

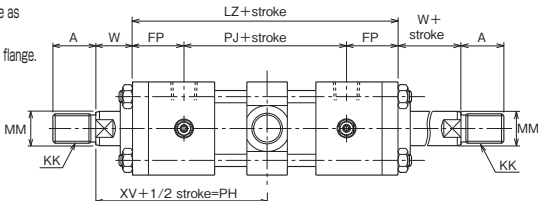

- The Switch Set (φ32 to φ140) is also within the standard stroke range.

70-140H-8/TH8  K 

### Minimum Available Strokes

Bore	Min. stroke	Bore	Min. stroke
φ140	6	φ200	18
φ150	0	φ224	27
φ160	8	φ250	27
φ180	12		

### With Boots

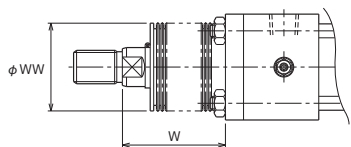

Dimension W  
Rod B/C

Material	φ32	φ40-φ50	φ63 to φ100	φ125 to φ200	φ224 to φ250
Nylon tarpaulin	1/3	stroke+X	1/3.5	stroke+X	1/4
Chloroprene	1/3	stroke+X	1/4	stroke+X	1/5
	1/6	stroke+X			
Conex	1/2	stroke+X	1/2.5	stroke+X	1/3
	1/3	stroke+X	1/3	stroke+X	1/4
	1/3.5	stroke+X	1/4	stroke+X	1/4.5
	1/4	stroke+X	1/4	stroke+X	1/4.5

- If the calculated value has a fractional part, round it up.

	Standard	Semi-standard	
Material	Nylon tarpaulin	Chloroprene	Conex
Heat proof	80°C	130°C	200°C

### Notes

- Remember that the heat proof field in the table above shows the allowable temperatures for the boots, not for the cylinder.
- Conex is the registered trademark of Teijin Limited.
- The boots have been mounted at our factory prior to delivery.

### Rod A

Material	φ40	φ50 to φ80	φ100 to φ160
Nylon tarpaulin	1/3.5	stroke+X	1/4
Chloroprene	1/3	stroke+X	1/5
Conex	1/2.5	stroke+X	1/3
	1/3	stroke+X	1/3.5
	1/4	stroke+X	1/4

### Dimensional Table

Symbol Bore	Rod B							Rod C							Rod A							
	A	B	KK	MM	S	SL	VD	A	B	KK	MM	S	SL	VD	A	B	KK	MM	S	SL	VD	
φ32	25	φ34	M16×1.5	φ18	14	10	10	—	—	—	—	—	—	—	—	—	—	—	—	—	—	—
φ40	30	φ40	M20×1.5	φ22.4	19	11	10	25	φ36	M16×1.5	φ18	14	10	10	35	φ43	M24×1.5	φ28	24	14	17	—
φ50	35	φ46	M24×1.5	φ28	24	14	10	30	φ40	M20×1.5	φ22.4	19	11	10	45	φ50	M30×1.5	φ35.5	30	16	17	—
φ63	45	φ55	M30×1.5	φ35.5	30	16	10	35	φ46	M24×1.5	φ28	24	14	10	60	φ65	M39×1.5	φ45	41	20	19	—
φ80	60	φ65	M39×1.5	φ45	41	20	10	45	φ55	M30×1.5	φ35.5	30	16	9	75	φ80	M48×1.5	φ56	50	23	20	—
φ100	75	φ80	M48×1.5	φ56	50	23	10	60	φ65	M39×1.5	φ45	41	20	10	95	φ95	M64×2	φ71	65	27	23	—
φ125	95	φ95	M64×2	φ71	65	27	10	75	φ80	M48×1.5	φ56	50	23	10	120	φ115	M80×2	φ90	85	33	17	—
φ140	110	φ105	M72×2	φ80	75	31	10	80	φ85	M56×2	φ63	55	24	10	140	φ125	M95×2	φ100	—	—	—	Drill hole
φ150	115	φ110	M76×2	φ85	80	33	10	85	φ90	M60×2	φ67	60	30	10	140	φ125	M95×2	φ100	—	—	—	Drill hole
φ160	120	φ115	M80×2	φ90	85	33	10	95	φ95	M64×2	φ71	65	27	10	150	φ140	M100×2	φ112	—	—	—	Drill hole
φ180	140	φ125	M95×2	φ100	—	—	—	110	φ105	M72×2	φ80	75	31	10	—	—	—	—	—	—	—	—
φ200	150	φ140	M100×2	φ112	—	—	—	120	φ115	M80×2	φ90	85	33	10	—	—	—	—	—	—	—	—
φ224	180	φ150	M120×2	φ125	—	—	—	140	φ125	M95×2	φ100	—	—	10	—	—	—	—	—	—	—	—
φ250	195	φ170	M130×2	φ140	—	—	—	150	φ140	M100×2	φ112	—	—	10	—	—	—	—	—	—	—	—

Symbol Bore	BB	BD	E	EE	FP	HL	JR	LZ	Min. PH		PJ	TD	TL	TM	UM	W			XV			ZJ		
									B·C	A						B·C	A	B·C	A	B·C	A			
φ32	11	28	□58	Rc3/8	38	141	R2	166	105	—	90	φ20e9	20	58 <sup>0</sup> <sub>-0.3</sub>	98	30	—	113	—	171	—	—	—	
φ40	11	28	□65	Rc3/8	38	141	R2	166	105	110	90	φ20e9	20	69 <sup>0</sup> <sub>-0.3</sub>	109	30	35	113	118	171	176	—	—	
φ50	11	33	□76	Rc1/2	42	155	R2.5	182	113.5	124.5	98	φ25e9	25	85 <sup>0</sup> <sub>-0.35</sub>	135	30	41	121	132	185	196	—	—	
φ63	13	43	□90	Rc1/2	46	163	R2.5	194	127.5	140.5	102	φ31.5e9	31.5	98 <sup>0</sup> <sub>-0.35</sub>	161	35	48	132	145	198	211	—	—	
φ80	16	43	□110	Rc3/4	56	184	R2.5	222	140.5	156.5	110	φ31.5e9	31.5	118 <sup>0</sup> <sub>-0.35</sub>	181	35	51	146	162	219	235	—	—	
φ100	18	53	□135	Rc3/4	58	192	R3	232	152.5	169.5	116	φ40e9	40	145 <sup>0</sup> <sub>-0.40</sub>	225	40	57	156	173	232	249	—	—	
φ125	21	58	□165	Rc1	67	220	R3	264	174	186	130	φ50e9	50	175 <sup>0</sup> <sub>-0.40</sub>	275	45	57	177	189	265	277	—	—	
φ140	22	78	□185	Rc1	69	230	R4	276	191	198	138	φ63e9	63	195 <sup>0</sup> <sub>-0.46</sub>	321	50	57	188	195	280	287	—	—	
φ150	25	78	□196	Rc1	71	240	R4	288	193	200	146	φ63e9	63	206 <sup>0</sup> <sub>-0.46</sub>	332	50	57	194	201	290	297	—	—	
φ160	25	88	□210	Rc1	74	253	R4	304	211	213	156	φ71e9	71	218 <sup>0</sup> <sub>-0.46</sub>	360	55	57	207	209	308	310	—	—	
φ180	27	98	□235	Rc1 1/4	75	275	R4	322	225	—	172	φ80e9	80	243 <sup>0</sup> <sub>-0.46</sub>	403	55	—	216	—	330	—	—	—	
φ200	29	108	□262	Rc1 1/2	85	301	R5	354	244	—	184	φ90e9	90	272 <sup>0</sup> <sub>-0.52</sub>	452	55	—	232	—	356	—	—	—	
φ224	34	117	□292	Rc1 1/2	89	305	R5	362	257.5	—	184	φ100e9	100	300 <sup>0</sup> <sub>-0.52</sub>	500	60	—	241	—	365	—	—	—	
φ250	37	117	□325	Rc2	106	346	R5	412	287.5	—	200	φ100e9	100	335 <sup>0</sup> <sub>-0.57</sub>	535	65	—	271	—	411	—	—	—	

- The tolerance of B is h8, and that of MM is f8.

### With Boots

Symbol Bore	Rod B	Rod C	Rod A	φ32	φ40	φ50	φ63	φ80	φ100	φ125	φ140	φ150	φ160	φ180	φ200	φ224	φ250
X	45	45	45	55	55	55	65	65	65	65	65	65	65	65	65	80	80

### Switch Set

70H-8R	2	SD	Bore	B	B	200	-	A	B	Sensor symbol	Sensor quantity
140H-8R	2	SD	Bore	B	B	200	-	A	B	Sensor symbol	Sensor quantity

AX type (Reed sensor), AX type (Solid state sensor)

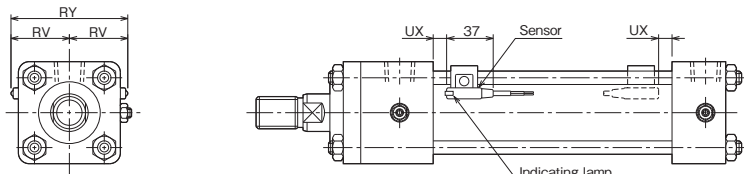

WR type (Reed sensor), WS type (Solid state sensor/2-wire, 2-LED type) (Cutting oil proof type)

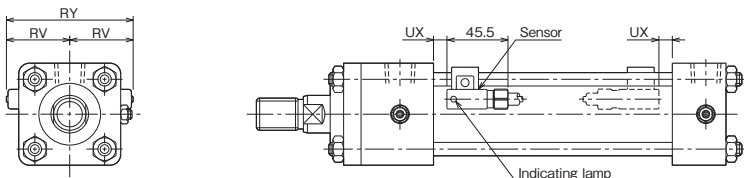

### Minimum dimensions PH and PN of Switch Set Cylinders 70/140H-8R

• TC style

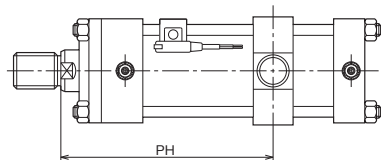

• FK style

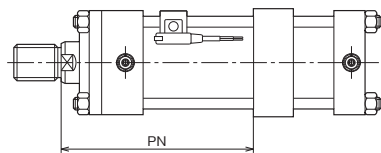

• The minimum dimensions PH and PN of a Switch Set Cylinder are the dimensions obtained when the sensor is mounted on the rod side and the trunnion is moved toward the rod side as far as possible.

When boots are provided, dimension W changes. Specify dimension PH or PN.

### Dimensional Table

Symbol	RV			RY			UX				Min. dimension PH				Min. dimension PN			
	AX type AX205W	SR type	WR/WS type	AX type AX205W	SR type	WR/WS type	AX type AX205W	SR type	WR type	WS type	AX type AX205W	SR type	WR type	WS type	AX type AX205W	SR type	WR type	WS type
φ32	36	40	39	72	80	78	13	6	9	12	171	181	190	193	157	167	176	179
φ40	40	46	43	80	92	86	14	6	9	13	171	181	190	193	157	167	176	179
φ50	43	50	47	86	100	94	15	7	9	14	178.5	193.5	198.5	203.5	162	177	182	187
φ63	50	56	53	100	112	106	17	10	13	16	196.5	211.5	216.5	218.5	175	190	195	197
φ80	60	64	63	120	128	126	19	11	13	17	211.5	226.5	229.5	233.5	190	205	208	212
φ100	70	74	72	140	148	144	21	13	14	21	224.5	239.5	242.5	249.5	198	213	216	223
φ125	83	89	85	166	178	170	23	17	19	23	250	265	269	273	221	236	240	244
φ140	91	-	-	182	-	-	26	-	-	-	280	-	-	-	241	-	-	-

Note) Dimension UX indicates the optimum sensor mounting position for detection of stroke end.

### Operating Range and Hysteresis

Bore mm	Reed sensor						Solid state sensor									
	AX1 * *		SR type		WR type		AX2 * *		AX2 * * W		WS type					
	Operating range	Hysteresis	Operating range	Hysteresis	Operating range	Hysteresis	Operating range	Hysteresis	Operating range	Hysteresis	Operating range	Hysteresis				
φ32	4 to 14	2 or less	7 to 10	3 or less	4 to 9	2 or less	3 to 8	1 or less	9 to 12	2 or less	9 to 12	2 or less				
φ40			7 to 12		6 to 12				11 to 17		11 to 17					
φ50			7 to 12		6 to 12				11 to 17		11 to 17					
φ63			7 to 12		6 to 12				11 to 17		11 to 17					
φ80			7 to 12		6 to 12				11 to 17		11 to 17					
φ100	11 to 18	2 or less	10 to 16	3 or less	10 to 17	2 or less	4 to 10	1 or less	17 to 21	2 or less	17 to 21	2 or less				
φ125	5 to 15		9 to 15		5 to 12		17 to 21		17 to 21							
φ140	11 to 20		-		-		-		-		6 to 13		-	-	-	-

70-140H-8/TH8 [Bore]K CAD/DATA is available.

### Rod End Attachment

#### Rod eye (T-end)

φ32 to φ160

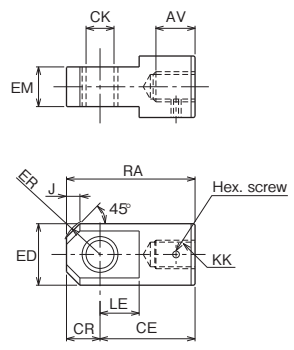

φ180 to φ250

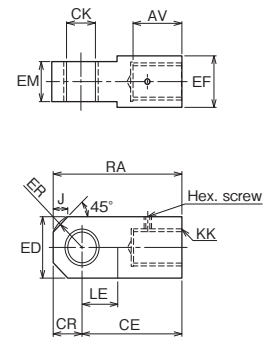

#### Rod eye with spherical bearing (S-end)

φ40 to φ63

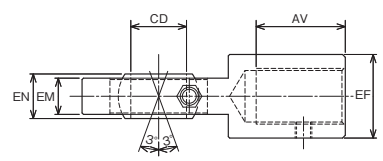

φ80 to φ125

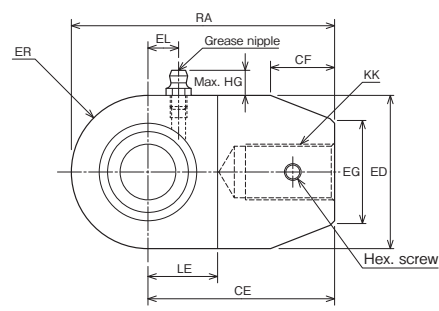
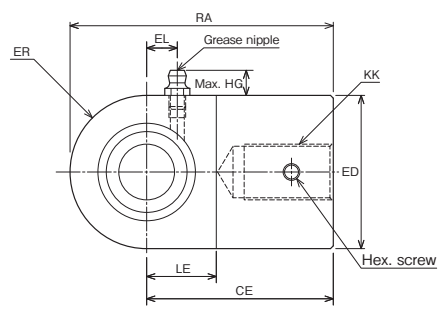
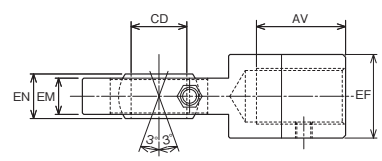

- Notes)
- The spherical bearings are not filled with grease. Lubricate appropriately through the grease nipple.
  - The bearing inner diameter and mounting width conform to JIS B8369.

### Dimensional Table/Rod eye (T-end)

Symbol Bore	Part number		AV		CE	CK	CR	ED	EF	EM	ER	J	KK		LE	RA
	Rod B	Rod C	Rod B	Rod C									Rod B	Rod C		
φ32	RTH-16-H	—	27	—	60	φ16H10	20	φ39	—	25 <sup>-0.1</sup> <sub>-0.4</sub>	R23	8	M16×1.5	—	23	80
φ40	RTH-20-H	RTH-16-H	32	27	60	φ16H10	20	φ39	—	25 <sup>-0.1</sup> <sub>-0.4</sub>	R23	8	M20×1.5	M16×1.5	23	80
φ50	RTH-24-H	RTH-20-1-H	37	32	70	φ20H10	25	φ49	—	31.5 <sup>-0.1</sup> <sub>-0.4</sub>	R29	10	M24×1.5	M20×1.5	28	95
φ63	RTH-30-H	RTH-24-1-H	47	37	115	φ31.5H10	35	φ62	—	40 <sup>-0.1</sup> <sub>-0.4</sub>	R39	15	M30×1.5	M24×1.5	43	150
φ80	RTH-39-H	RTH-30-H	62	47	115	φ31.5H10	35	φ62	—	40 <sup>-0.1</sup> <sub>-0.4</sub>	R39	15	M39×1.5	M30×1.5	43	150
φ100	RTH-48-H	RTH-39-1-H	77	62	145	φ40H10	40	φ79	—	50 <sup>-0.1</sup> <sub>-0.4</sub>	R45	20	M48×1.5	M39×1.5	55	185
φ125	RTH-64-H	RTH-48-1-H	97	77	180	φ50H10	50	φ100	—	63 <sup>-0.1</sup> <sub>-0.4</sub>	R54	30	M64×2	M48×1.5	65	230
φ140	RTH-72-H	RTH-56-H	112	82	225	φ63H10	65	φ130	—	80 <sup>-0.1</sup> <sub>-0.6</sub>	R74	30	M72×2	M56×2	85	290
φ150	RTH-76-H	RTH-60-H	117	87	225	φ63H10	65	φ130	—	80 <sup>-0.1</sup> <sub>-0.6</sub>	R74	30	M76×2	M60×2	85	290
φ160	RTH-80-H	RTH-64-1-H	122	97	240	φ71H10	70	φ140	—	80 <sup>-0.1</sup> <sub>-0.6</sub>	R77	40	M80×2	M64×2	90	310
φ180	RTH-95-H	RTH-72-1-H	142	112	280	φ80H10	80	160	130	100 <sup>-0.1</sup> <sub>-0.6</sub>	R90	40	M95×2	M72×2	100	360
φ200	RTH-100-H	RTH-80-1-H	152	122	310	φ90H10	90	180	140	125 <sup>-0.1</sup> <sub>-0.6</sub>	R99	50	M100×2	M80×2	120	400
φ224	RTH-120-H	RTH-95-1-H	182	142	370	φ100H10	100	200	170	125 <sup>-0.1</sup> <sub>-0.6</sub>	R112	50	M120×2	M95×2	130	470
φ250	RTH-130-H	RTH-100-1-H	197	152	370	φ100H10	100	200	180	125 <sup>-0.1</sup> <sub>-0.6</sub>	R112	50	M130×2	M100×2	130	470

### Dimensional Table/Rod eye with spherical bearing (S-end)

Symbol Bore	Part number		AV		CD	CE	CF	ED	EF	EG	EM	EN	ER	KK		LE	RA
	Rod B	Rod C	Rod B	Rod C										Rod B	Rod C		
φ40	RSH-20	RSH-16	32	27	φ20 <sup>0</sup> <sub>-0.012</sub>	67	—	55	30	—	13	16 <sup>0</sup> <sub>-0.12</sub>	R27.5	M20×1.5	M16×1.5	25	94.5
φ50	RSH-24	RSH-20-1	37	32	φ25 <sup>0</sup> <sub>-0.012</sub>	78	—	65	35	—	17	20 <sup>0</sup> <sub>-0.12</sub>	R32.5	M24×1.5	M20×1.5	31	110.5
φ63	RSH-30	RSH-24-1	47	37	φ30 <sup>0</sup> <sub>-0.012</sub>	98	—	80	45	—	19	22 <sup>0</sup> <sub>-0.12</sub>	R40	M30×1.5	M24×1.5	38	138
φ80	RSH-39	RSH-30-1	62	47	φ40 <sup>0</sup> <sub>-0.012</sub>	125	60	100	55	69	23	28 <sup>0</sup> <sub>-0.12</sub>	R50	M39×1.5	M30×1.5	48	175
φ100	RSH-48	RSH-39-1	77	62	φ50 <sup>0</sup> <sub>-0.012</sub>	152	50	120	70	93	30	35 <sup>0</sup> <sub>-0.12</sub>	R60	M48×1.5	M39×1.5	58	212
φ125	RSH-64	RSH-48-1	97	77	φ60 <sup>0</sup> <sub>-0.015</sub>	187	72	150	90	105	38	44 <sup>0</sup> <sub>-0.15</sub>	R75	M64×2	M48×1.5	72	262

### Dimensional Table/Grease nipple

Symbol Bore	Rod B			Rod C		
	Grease nipple type	EL	HG	Grease nipple type	EL	HG
φ40	JIS A type MT6×1	11	11	JIS A type MT6×1	11	11
φ50	JIS A type MT6×1	14	11	JIS A type MT6×1	14	11
φ63	JIS A type Rc1/8	15	15	JIS A type Rc1/8	15	15
φ80	JIS A type Rc1/8	20	15	JIS A type Rc1/8	20	15
φ100	JIS A type Rc1/8	24	15	JIS A type Rc1/8	24	15
φ125	JIS A type Rc1/8	28	15	JIS A type Rc1/8	28	15

### Rod clevis (Y-end) with pin

φ32 to φ80

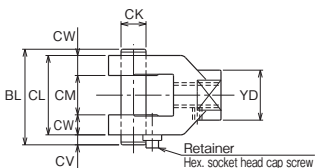

φ100

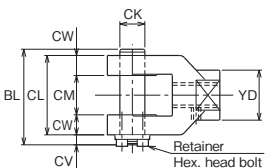

φ125 to φ250

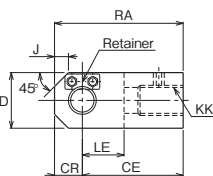
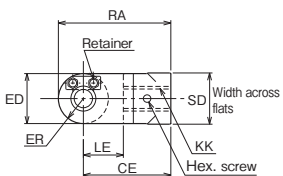
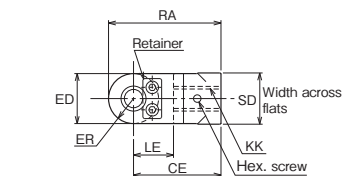
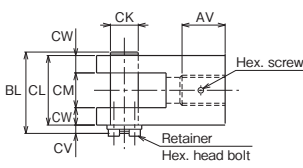

### ●Delivery of rod end attachment (T-end or Y-end)

- When the lock nut and rod end attachment are additionally ordered

The rod end attachment and lock nut are temporarily assembled to the piston rod for delivery. Since the lock nut is not tightened, tighten it after adjusting the position of the rod end attachment. No hex. screw is supplied.

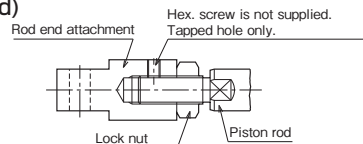

- When only the rod end attachment is additionally ordered (without lock nut)

The rod end attachment is tightened to the piston rod, and a drill hole is made on the piston rod for delivery. If the drill hole is unnecessary, give us such instructions.

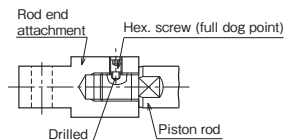

### Floating joint (F-end)

Note: 70H-8 Series only

Applicable series

- 70H-8
- 70H-8R
- 70H-8D
- 70H-8RD

Notes

- The insertion of the floating joint into the socket shall not equal or exceed the dimension of screw diameter. (Return the joint one or two turns after it gets into contact with the socket bottom, and fix it with a lock nut.) Excessive insertion can cause operation failure.
- DO NOT use together with CA, CS, CB, TA, and TC accessories.
- The lock nut is indispensable in using the floating joint. Please don't miss to order the lock nut with the floating joint.
- Make an order for the cylinder rod end lock nut at the same time.

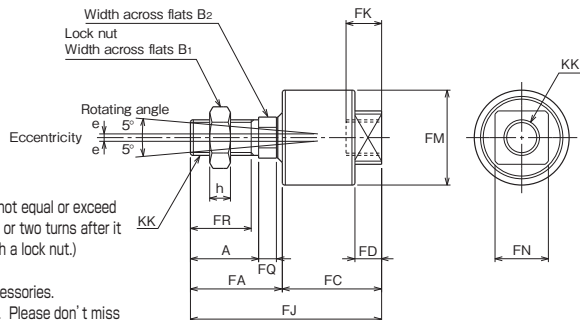

### Dimensional Table/Rod clevis (Y-end) with pin

Symbol	Part number		AV		BL	CE	CK	CL	CM	CR	CV	CW	ED	ER	J	KK		LE	RA	SD	YD
	Rod B	Rod C	Rod B	Rod C												Rod B	Rod C				
φ32	RYH-16-H	—	—	—	62	60	φ16 <sup>H10/18</sup>	50	25 <sup>+0.4/+0.1</sup>	—	7	12.5	32	R16	—	M16×1.5	—	27	76	32	32
φ40	RYH-20-H	RYH-16-H	—	—	62	60	φ16 <sup>H10/18</sup>	50	25 <sup>+0.4/+0.1</sup>	—	7	12.5	32	R16	—	M20×1.5	M16×1.5	27	76	32	32
φ50	RYH-24-H	RYH-20-1-H	—	—	76.5	70	φ20 <sup>H10/18</sup>	63.5	31.5 <sup>+0.4/+0.1</sup>	—	8	16	40	R20	—	M24×1.5	M20×1.5	32	90	41	40
φ63	RYH-30-H	RYH-24-1-H	—	—	93	115	φ31.5 <sup>H10/18</sup>	80	40 <sup>+0.4/+0.1</sup>	—	8	20	60	R30	—	M30×1.5	M24×1.5	50	145	60	60
φ80	RYH-39-H	RYH-30-H	—	—	93	115	φ31.5 <sup>H10/18</sup>	80	40 <sup>+0.4/+0.1</sup>	—	8	20	60	R30	—	M39×1.5	M30×1.5	50	145	60	60
φ100	RYH-48-H	RYH-39-1-H	—	—	117	145	φ40 <sup>H10/18</sup>	100	50 <sup>+0.4/+0.1</sup>	—	12	25	80	R40	—	M48×1.5	M39×1.5	60	185	80	80
φ125	RYH-64-H	RYH-48-1-H	97	77	143	180	φ50 <sup>H10/18</sup>	126	63 <sup>+0.6/+0.1</sup>	50	12	31.5	100	R54	30	M64×2	M48×1.5	70	230	—	—
φ140	RYH-72-H	RYH-56-H	112	82	183	225	φ63 <sup>H10/18</sup>	160	80 <sup>+0.6/+0.1</sup>	65	18	40	120	R72	30	M72×2	M56×2	90	290	—	—
φ150	RYH-76-H	RYH-60-H	117	87	183	225	φ63 <sup>H10/18</sup>	160	80 <sup>+0.6/+0.1</sup>	65	18	40	120	R72	30	M76×2	M60×2	90	290	—	—
φ160	RYH-80-H	RYH-64-1-H	122	97	183	240	φ71 <sup>H10/18</sup>	160	80 <sup>+0.6/+0.1</sup>	70	18	40	140	R77	40	M80×2	M64×2	100	310	—	—
φ180	RYH-95-H	RYH-72-1-H	142	112	210	280	φ80 <sup>H10/18</sup>	180	100 <sup>+0.6/+0.1</sup>	80	24	40	160	R90	40	M95×2	M72×2	110	360	—	—
φ200	RYH-100-H	RYH-80-1-H	152	122	260	310	φ90 <sup>H10/18</sup>	230	125 <sup>+0.6/+0.1</sup>	90	24	52.5	180	R99	50	M100×2	M80×2	130	400	—	—
φ224	RYH-120-H	RYH-95-1-H	182	142	280	370	φ100 <sup>H10/18</sup>	250	125 <sup>+0.6/+0.1</sup>	100	24	62.5	200	R112	50	M120×2	M95×2	140	470	—	—
φ250	RYH-130-H	RYH-100-1-H	197	152	280	370	φ100 <sup>H10/18</sup>	250	125 <sup>+0.6/+0.1</sup>	100	24	62.5	200	R112	50	M130×2	M100×2	140	470	—	—

Note) When the rod clevis (Y-end) is mounted to the LC style with the pin vertically, it may interfere with the rib. In such a case, consult us.

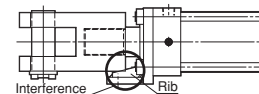

### Dimensional Table/Floating joint (F-end)

Applicable bore		Part number	A	B1	B2	e	FA	FC	FD	FJ	FK	FM	FN	FQ	FR	h	KK
Rod B	Rod C																
φ32	φ40	RFH-16	32	22	17	1.5	43	46	13	89	16	φ40	24	8	28	10	M16×1.5
φ40	φ50	RFH-20	40	27	22	2	53	57	15	110	22	φ50	30	9	35	12	M20×1.5
φ50	φ63	RFH-24	46	32	24	2.5	62	67	18	129	24	φ64	36	12	41	14	M24×1.5
φ63	φ80	RFH-30	58	41	32	2.5	78	83	21	161	30	φ76	46	14	52	17	M30×1.5

CAD/DATA

70-140H-8/TH8 [Bore] K is available.



When rod end attachment is required (rod dia. A type)

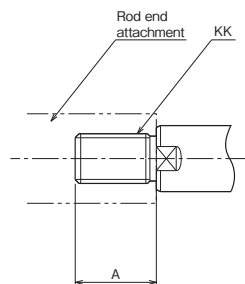

- It is recommended to change the thread diameter KK to the thread diameter of rod B (e.g. M30×1.5 → M24×1.5 in case of a 50-mm bore cylinder) and fit the rod end attachment for the rod B. In this case, specify dimensions A and KK.

## Lock Nut

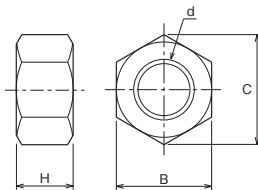

The standard fitting length of the rod end attachment and piston rod is about 80% of the thread diameter. If the fitting length is insufficient due to the use of the lock nut, it is necessary to increase the thread length (dimension A) as shown below.

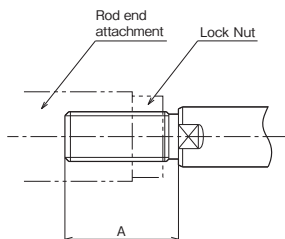

## Dimensional Table

Symbol	Dimension of rod A threaded portion		Dimension of rod B threaded portion		Rod end attachment for dimension of rod B threaded portion		
	A	KK	A	KK	Rod eye	Rod clevis	Floating joint
φ40	35	M24×1.5	30	M20×1.5	RTH-20-H	RYH-20-H	RFH-20
φ50	45	M30×1.5	35	M24×1.5	RTH-24-H	RYH-24-H	RFH-24
φ63	60	M39×1.5	45	M30×1.5	RTH-30-H	RYH-30-H	RFH-30
φ80	75	M48×1.5	60	M39×1.5	RTH-39-H	RYH-39-H	—
φ100	95	M64×2	75	M48×1.5	RTH-48-H	RYH-48-H	—
φ125	120	M80×2	95	M64×2	RTH-64-H	RYH-64-H	—
φ140	140	M95×2	110	M72×2	RTH-72-H	RYH-72-H	—
φ150	140	M95×2	115	M76×2	RTH-76-H	RYH-76-H	—
φ160	150	M100×2	120	M80×2	RTH-80-H	RYH-80-H	—

## Dimensional Table/Lock nut

Symbol	Bore	Rod B				Rod C				Rod A							
		Part number	B	C	d	H	Part number	B	C	d	H	Part number	B	C	d	H	
φ32	LNH-16F-H	22	25.4	M16×1.5	10	—	—	—	—	—	—	—	—	—	—	—	—
φ40	LNH-20F-H	27	31.2	M20×1.5	12	LNH-16F-H	22	25.4	M16×1.5	10	LNH-24F-H	32	37.0	M24×1.5	14	—	—
φ50	LNH-24F-H	32	37.0	M24×1.5	14	LNH-20F-H	27	31.2	M20×1.5	12	LNH-30F-H	41	47.3	M30×1.5	17	—	—
φ63	LNH-30F-H	41	47.3	M30×1.5	17	LNH-24F-H	32	37.0	M24×1.5	14	LNH-39F-H	55	63.5	M39×1.5	20	—	—
φ80	LNH-39F-H	55	63.5	M39×1.5	20	LNH-30F-H	41	47.3	M30×1.5	17	LNH-48F-H	70	80.8	M48×1.5	26	—	—
φ100	LNH-48F-H	70	80.8	M48×1.5	26	LNH-39F-H	55	63.5	M39×1.5	20	LNH-64F-H	90	104	M64×2	35	—	—
φ125	LNH-64F-H	90	104	M64×2	35	LNH-48F-H	70	80.8	M48×1.5	26	LNH-80F-H	110	127	M80×2	43	—	—
φ140	LNH-72F-H	100	115	M72×2	38	LNH-56F-H	80	92.4	M56×2	30	LNH-95F-H	130	150	M95×2	47	—	—
φ150	LNH-76F-H	105	121	M76×2	40	LNH-60F-H	85	98.1	M60×2	33	LNH-95F-H	130	150	M95×2	47	—	—
φ160	LNH-80F-H	110	127	M80×2	43	LNH-64F-H	90	104	M64×2	35	LNH-100F-H	135	156	M100×2	50	—	—
φ180	LNH-95F-H	130	150	M95×2	47	LNH-72F-H	100	115	M72×2	38	—	—	—	—	—	—	—
φ200	LNH-100F-H	135	156	M100×2	50	LNH-80F-H	110	127	M80×2	43	—	—	—	—	—	—	—
φ224	LNH-120F-H	165	191	M120×2	60	LNH-95F-H	130	150	M95×2	47	—	—	—	—	—	—	—
φ250	LNH-130F-H	180	208	M130×2	65	LNH-100F-H	135	156	M100×2	50	—	—	—	—	—	—	—

Symbol	Dimension A		
	Rod A	Rod B	Rod C
φ32	—	40	—
φ40	50	45	40
φ50	60	50	45
φ63	80	60	50
φ80	95	80	60
φ100	125	95	80
φ125	155	125	95
φ140	180	140	105
φ150	180	150	120
φ160	190	155	125
φ180	—	180	140
φ200	—	190	155
φ224	—	230	180
φ250	—	250	190

## Parallel Pin

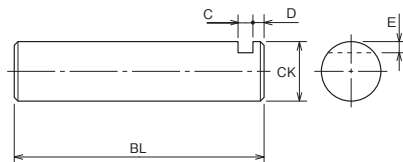

## Dimensional Table/Parallel pin

Symbol Bore	BL	C	CK	D	E
φ32	62	4	φ16	3	3
φ40	62	4	φ16	3	3
φ50	76.5	5	φ20	3	3
φ63	93	5	φ31.5	3	4.75
φ80	93	5	φ31.5	3	4.75
φ100	117	7	φ40	5	5
φ125	143	7	φ50	5	5
φ140	183	10	φ63	8	8
φ150	183	10	φ63	8	8
φ160	183	10	φ71	8	8

● The tolerance of CK is f8.

## Retainer

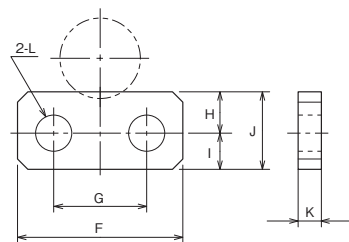

## Dimensional Table/Retainer

Symbol Bore	F	G	H	I	J	K	L	Retainer mounting bolt size
φ32	25	14	7	7	14	3	φ6.5	M6
φ40	25	14	7	7	14	3	φ6.5	M6
φ50	32	18	7.5	7.5	15	4.5	φ7	M6
φ63	32	18	7.5	7.5	15	4.5	φ7	M6
φ80	32	18	7.5	7.5	15	4.5	φ7	M6
φ100	50	30	10	10	20	6	φ10	M8
φ125	65	40	12	10	22	6	φ12	M10
φ140	75	48	17	13	30	9	φ14	M12
φ150	75	48	17	13	30	9	φ14	M12
φ160	75	48	17	13	30	9	φ14	M12



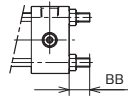
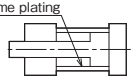
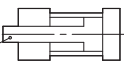
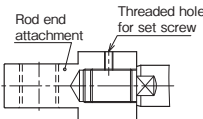
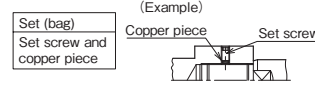
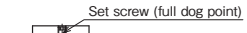
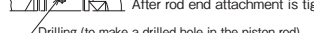

### ✦ The semi-standard ordering system

The following contents can be easily specified using the semi-standard symbols and specification symbols (position/dimension/material symbols).

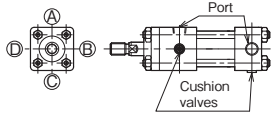
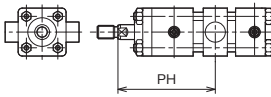
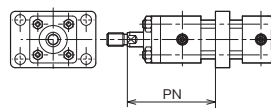
How to order **Series** **Model number** - X **Semi-standard symbol** **Position/Dimension/Material symbols**

Order contents	Semi- ① standard symbol	Position		Dimension		Material	
		② Symbol	Description	③ Symbol	Description	④ Symbol	Description
<b>■ Tie rods extension</b>  Notes 1) Tolerance of dimension BB is about 2 mm due to elongation by tightening. When precise dimension BB is required, specify the value. 2) For the LB or LC style, only upper two tie rods (on the side opposite to the accessory side) can be extended. For flange or clevis type, four tie rods on the side without the accessory can be extended.	STD	TD-RS	Rod side	BB- <input type="checkbox"/>	<input type="checkbox"/> is a desired dimension BB of up to 70 mm.	—	—
		TD-HS	Cap side				
TD-BS	Both sides						
Example		To specify SD style with dimension BB of 50 mm on both sides 70H-8R 2SD80BB100-ABAH2-X STD TD-BS, BB-50					
<b>■ Hard chrome plated on the inside of cylinder tube (standard type only)</b>  Note) Consult us for any special thickness of chrome plating other than 0.02 mm.	STB	—	—	BG-0.02	Plating thickness 0.02 mm	—	—
	Example	To plate the tube inner surface 0.02 mm in thickness 70H-8 2LB80BB100-AB-X STB BG-0.02					
<b>■ Stainless steel piston rod (φ40 to φ100)</b> Rod: Stainless steel  Note) Consult us for any special requirement other than material SUS304 or 0.02 mm thickness of chrome plating.	SPR	—	—	—	—	PR-10	Material: SUS304 Plating thickness 0.02mm
	Example	To specify piston rod made of SUS304 with plating thickness of 0.02 mm 70H-8R 2LB80BB100-ABAH2-X SPR PR-10					
<b>■ Rod end attachments (T, Y, S) with a set screw and a copper piece (φ32 to φ160)</b>  (Example)  Set (bag) Set screw and copper piece	MDC	—	—	—	—	—	—
	Example	No need to specify the material/dimension/position symbol. Example 1) When it is required to deliver the cylinder with a set screw and a copper piece attached to the Y-end (to be finally tightened by the customer) without a drill hole. 70H-8R 2CB80BB100-ABAH2-T-X MDC <b>[CAUTION]</b> The cylinder will be delivered with the rod end attachment temporarily mounted on the rod. After making the final adjustment, firmly tighten the rod end attachment, fit the copper piece into the set screw hole, and tighten the set screw. ★ Adhesive has been applied to the set screw for prevention of loosening. However, the effect of the adhesive varies depending on the conditions of use, etc. Confirm the effect by yourself. (Reference) Standard cylinders (without specifying the symbol 'MDC') will be delivered in the following state.  Set screw (full dog point) After rod end attachment is tightened  Drilling (to make a drilled hole in the piston rod)					

Order contents	Semi- ① standard symbol	Position		Dimension		Material	
		② Symbol	Description	② Symbol	Description	② Symbol	Description
<b>■ Change of port and cushion valve positions on the cap side</b> 	PPC	PC- <input type="checkbox"/>	<input type="checkbox"/> indicates the port and cushion valve positions on the cap side.	—	—	—	—
	Example	To change the port and cushion valve positions from the cap side to the rod side (AB on rod side, BC on cap side) 70H-8 2LA80BB100-AB-X PPC PC-BC					
<b>■ Water-glycol working fluid</b> Notes 1) Iron tubing (standard type) is plated with hard chrome and tested with water-glycol fluid. 2) Stainless steel tubing (Switch Set) is not plated in conformity with the standard and tested with water-glycol fluid.	FWF	—	—	—	—	WF-WG	WF-WG: Water-glycol fluid
	Example	70H-8 6LB80BB100-AB-X FWF WF-WG					
<b>■ Intermediate trunnion location change (dimension PH)</b> 	MTC	—	—	TCPH- <input type="checkbox"/>	<input type="checkbox"/> is a new dimension.	—	—
	Example	To change dimension PH to 360 mm 70H-8R 2TC63BB500-AB-X MTC TCPH-360					
<b>■ Intermediate flange location change (dimension PN)</b> 	MFK	—	—	FKPN- <input type="checkbox"/>	<input type="checkbox"/> is a new dimension.	—	—
	Example	To change dimension PH to 1100 mm 140H-8 2FK80BB1800-AB-X MFK FKPN-1100					

Order contents	Semi- ① standard symbol	Position		Dimension		Material									
		② Symbol	Description	③ Symbol	Description	④ Symbol	Description								
<b>Additional port of bushing</b>   <p>Notes 1) Select a reduced port size after mounting a bushing. 2) For reduction by more than two steps by using a bushing, consult us.</p>	PBS	—	—	RC-1.00	Rc1/8	—	—								
				RC-2.00	Rc1/4										
				RC-3.00	Rc3/8										
				RC-4.00	Rc1/2										
				RC-6.00	Rc3/4										
				RC-8.00	Rc1										
				RC-10.00	Rc1 1/4										
RC-12.00	Rc1 1/2														
Example		To reduce the port size to Rc1/2 by mounting a bushing to 140H-8 CA style 80-mm bore cylinder (standard port size Rc3/4) 140H-8 2CA80BB300-AB-X PBS RC-4.00													
<b>Reduction of Rc thread port size (φ32 to φ160)</b>  ★Specify the size to reduce the port size without using a bushing.   <p>Inapplicable to: ● All types of rod A ● Rod B or C with LA style</p>	Semi- ① standard symbol	Specify the size only		Port size selectable for cylinder bore (○: Standard port size)											
		PRT	③ Symbol	Description	32	40	50	63	80	100	125	140	150	160	
			RC-1.00	Rc1/8	○	○	×	×	×	×	×	×	×	×	×
			RC-2.00	Rc1/4	○	○	○	○	×	×	×	×	×	×	×
			RC-3.00	Rc3/8	◎	◎	○	○	○	○	×	×	×	×	×
			RC-4.00	Rc1/2	×	×	◎	◎	○	○	○	○	○	○	○
			RC-6.00	Rc3/4	×	×	×	×	◎	◎	○	○	○	○	○
			RC-8.00	Rc1	×	×	×	×	×	×	◎	◎	◎	◎	◎
			RC-10.00	Rc1 1/4	×	×	×	×	×	×	×	×	×	×	×
			Note	To reduce the cover port directly to Rc3/8 without mounting a bushing to 63-mm bore cylinder (standard port size Rc1/2) 70H-8R 2CA80BB100-ABAH2-X PRT RC-3.00											
<b>Reduction of NPT thread port size (φ32 to φ160)</b>  Note) Select a standard port size and a reduced port size.   <p>Inapplicable to: ● All types of rod A ● Rod B or C with LA style</p>	Semi- ① standard symbol		Specify the size only		Port size selectable for cylinder bore (○: Standard port size)										
		PTN	③ Symbol	Description	32	40	50	63	80	100	125	140	150	160	
			N-1.00	NPT1/8	○	○	×	×	×	×	×	×	×	×	×
			N-2.00	NPT1/4	○	○	○	○	×	×	×	×	×	×	×
			N-3.00	NPT3/8	◎	◎	○	○	○	○	×	×	×	×	×
			N-4.00	NPT1/2	×	×	◎	◎	○	○	○	○	○	○	○
			N-6.00	NPT3/4	×	×	×	×	◎	◎	○	○	○	○	○
			N-8.00	NPT1	×	×	×	×	×	×	◎	◎	◎	◎	◎
			N-10.00	NPT1 1/4	×	×	×	×	×	×	×	×	×	×	×
			Cap side	To order the standard port size (○), see the following.											
Note	To reduce the port size for a cylinder bore of 50 mm (standard size 1/2) to NPT 3/8 70H-8 2CB50BB100-NAB-X PTN N-3.00														
<b>G thread type/NPT thread type (φ32 to φ160) (only standard port size)</b>   <p>For the G thread port size, refer to the dimensional table in the model specification field.</p>	The thread type can be specified by the cylinder model number without using the semi-standard symbol and specification symbols. Example) 70H-8 2LA50BB100- G A B -TL														
	G: Port G thread type    N: NPT thread type Port position Cushion valve position														

How to order Series Model number - × Semi-standard symbol Position/Dimension/Material symbols

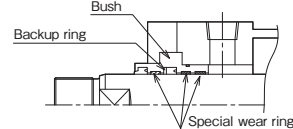
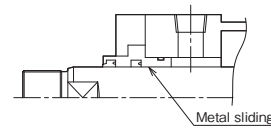
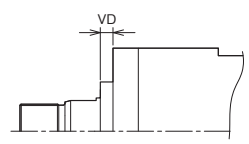
Order contents	Semi- ① standard symbol	Position		Dimension		Material																																										
		② Symbol	Description	③ Symbol	Description	④ Symbol	Description																																									
<b>Reinforced bearing type (for resistance to lateral load)</b>  Type for improving the load resistance of the bearing block by using abrasion-resistant special wear rings for high load in the gland bush sliding part. Since the dimensions and appearance are the same as those of the standard type, the cylinder can be mounted in the same manner.  	MBH	—	—	—	—	—	—																																									
								Example	Add 'MBH' to the end of the symbol for ordering (specification symbols are unnecessary).  140H-8R 2CB140BB1200-ABAH2 MBH  (Reference) The standard gland has metal sliding surfaces as shown below.  																																							
<b>Outline drawing</b>  	Rods A and B have the same dimensions as the standard type. For rod C, see the following dimensional table.																																															
	<b>Dimensional Table</b> <table border="1" style="width: 100%; border-collapse: collapse; text-align: center;"> <thead> <tr> <th rowspan="2">Rod type</th> <th colspan="2">Rod C</th> </tr> <tr> <th colspan="2">VD</th> </tr> <tr> <th>Dimension symbol</th> <th colspan="2">VD</th> </tr> <tr> <th rowspan="2">Mounting style</th> <th>SD·LA·LB·LC·FA·FB·FC·FD·FK·FZ·CA·CB·CS·TA·TC</th> <th colspan="2">FY</th> </tr> <tr> <th>Bore</th> <th>MBH</th> <th>MBH</th> </tr> </thead> <tbody> <tr> <td>φ40</td> <td>10</td> <td>10</td> </tr> <tr> <td>φ50</td> <td>9</td> <td>6</td> </tr> <tr> <td>φ63</td> <td>10</td> <td>10</td> </tr> <tr> <td>φ80</td> <td>9</td> <td>8</td> </tr> <tr> <td>φ100</td> <td>10</td> <td>8</td> </tr> <tr> <td>φ125</td> <td>10</td> <td>9</td> </tr> <tr> <td>φ140</td> <td>10</td> <td>10</td> </tr> <tr> <td>φ150</td> <td>10</td> <td>10</td> </tr> <tr> <td>φ160</td> <td>10</td> <td>9</td> </tr> </tbody> </table>							Rod type	Rod C		VD		Dimension symbol	VD		Mounting style	SD·LA·LB·LC·FA·FB·FC·FD·FK·FZ·CA·CB·CS·TA·TC	FY		Bore	MBH	MBH	φ40	10	10	φ50	9	6	φ63	10	10	φ80	9	8	φ100	10	8	φ125	10	9	φ140	10	10	φ150	10	10	φ160	10
Rod type	Rod C																																															
	VD																																															
Dimension symbol	VD																																															
Mounting style	SD·LA·LB·LC·FA·FB·FC·FD·FK·FZ·CA·CB·CS·TA·TC	FY																																														
	Bore	MBH	MBH																																													
φ40	10	10																																														
φ50	9	6																																														
φ63	10	10																																														
φ80	9	8																																														
φ100	10	8																																														
φ125	10	9																																														
φ140	10	10																																														
φ150	10	10																																														
φ160	10	9																																														

### Change of Rod End Shape

You can specify the shape and dimension of the rod end as shown below using the semi-standard symbols and dimension symbols.  
(No need to specify the dimension symbol if you order a cylinder with the basic dimension. Specify only the semi-standard symbol.)

How to order **Series** **Model number** - × **Semi-standard symbol** **Dimension symbol** (Specify only when the dimension differs from the basic dimension.)

— KM and KP need to be specified as a pair.

Example 1)

**A53**

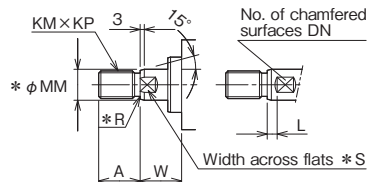

● Bore: 63 mm, rod C, rod end shape: A53, A=50, W=50, screw: M22 x 1.5, 2 surfaces chamfered, position of width across flats L=10  
70H-8 2FA63CB200-AB-X A53 A-50, KM-22, KP-1.5, L-10, W-50

Example 2)

**A54**

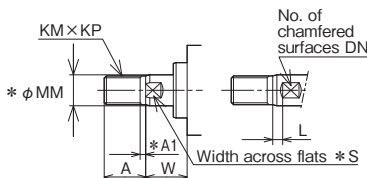

● Bore: 63 mm, rod C, rod end shape: A54, with basic dimensions

Note) In case of A54, if KM and KP are changed, dimension A1 is changed as shown below.

KP (pitch)	Dimension A1
1.75 or less	4
2	5
2.5 or more	KP (pitch) × 2

### Rod C Special Rod End Shapes

**A00**

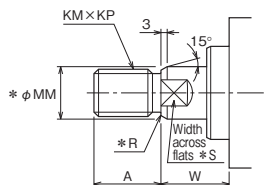

Table of Basic Dimensions (Standard dimensions)

Bore	A	KM	KP	*MM	*R	*S	W
φ40	25	M16	1.5	φ18	1	14	30
φ50	30	M20	1.5	φ22.4	1	19	30
φ63	35	M24	1.5	φ28	1	24	35
φ80	45	M30	1.5	φ35.5	1.6	30	35
φ100	60	M39	1.5	φ45	1.6	41	40
φ125	75	M48	1.5	φ56	1.6	50	45
φ140	80	M56	2	φ63	2	55	50
φ150	85	M60	2	φ67	2	60	50
φ160	95	M64	2	φ71	2	65	55
φ180	110	M72	2	φ80	2	75	55
φ200	120	M80	2	φ90	2	85	55
φ224	140	M95	2	φ100	2	Drill hole	60
φ250	150	M100	2	φ112	2		65

**A51**

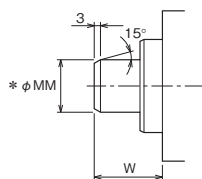

Table of Basic Dimensions

Bore	*MM	W
φ40	φ18	30
φ50	φ22.4	30
φ63	φ28	35
φ80	φ35.5	35
φ100	φ45	40
φ125	φ56	45
φ140	φ63	50
φ150	φ67	50
φ160	φ71	55
φ180	φ80	55
φ200	φ90	55
φ224	φ100	60
φ250	φ112	65

● The \*-marked dimensions are fixed.  
● If it is necessary to change the fixed dimensions, consult us.

### Rod C

**A53**

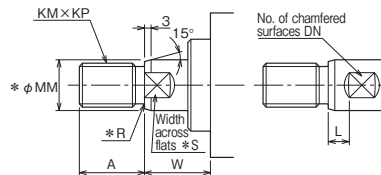

Table of Basic Dimensions

Bore	A	DN	KM	KP	L	*MM	*R	*S	W
φ40	25	2	M16	1.5	0	φ18	1	14	30
φ50	30	2	M20	1.5	0	φ22.4	1	19	30
φ63	35	2	M24	1.5	0	φ28	1	24	35
φ80	45	2	M30	1.5	0	φ35.5	1.6	30	35
φ100	60	2	M39	1.5	0	φ45	1.6	41	40
φ125	75	2	M48	1.5	0	φ56	1.6	50	45
φ140	80	2	M56	2	0	φ63	2	55	50
φ150	85	2	M60	2	0	φ67	2	60	50
φ160	95	2	M64	2	0	φ71	2	65	55

Use this shape to move the width across flats S of 'A00'.

**A54**

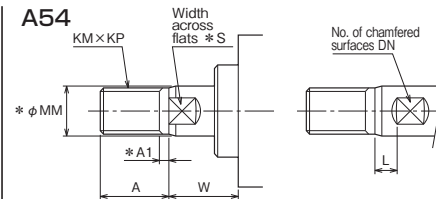

Table of Basic Dimensions

Bore	A	*A1	DN	KM	KP	L	*MM	*S	W
φ40	25	4	2	M16	1.5	0	φ18	14	30
φ50	30	4	2	M20	1.5	0	φ22.4	19	30
φ63	35	4	2	M24	1.5	0	φ28	24	35
φ80	45	4	2	M30	1.5	0	φ35.5	30	35
φ100	60	4	2	M39	1.5	0	φ45	41	40
φ125	75	4	2	M48	1.5	0	φ56	50	45
φ140	80	5	2	M56	2	0	φ63	55	50
φ150	85	5	2	M60	2	0	φ67	60	50
φ160	95	5	2	M64	2	0	φ71	65	55
φ180	110	5	2	M72	2	0	φ80	75	55
φ200	120	5	2	M80	2	0	φ90	85	55
φ224	140	5	Drill hole	M95	2	Drill hole	φ100	Drill hole	60
φ250	150	5	Drill hole	M100	2	Drill hole	φ112	Drill hole	65

**A81**

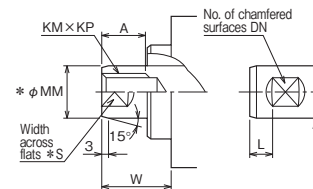

Table of Basic Dimensions

Bore	A	DN	KM	KP	L	*MM	*S	W
φ40	15	2	M12	1.75	0	φ18	14	30
φ50	20	2	M16	2	0	φ22.4	19	30
φ63	24	2	M20	2.5	0	φ28	24	35
φ80	33	2	M27	3	0	φ35.5	30	35
φ100	36	2	M30	3.5	0	φ45	41	40
φ125	45	2	M39	4	0	φ56	50	45
φ140	54	2	M45	2	0	φ63	55	50
φ150	54	2	M45	2	0	φ67	60	50
φ160	58	2	M48	2	0	φ71	65	55

This shape applies only to 7 MPa type.  
For the 14 MPa type, consult us.

Note) The number of chamfered surfaces DN is 2 (standard) or 4 only.

● The \*-marked dimensions are fixed.  
● If it is necessary to change the fixed dimensions, consult us.

### Rod B Special Rod End Shapes

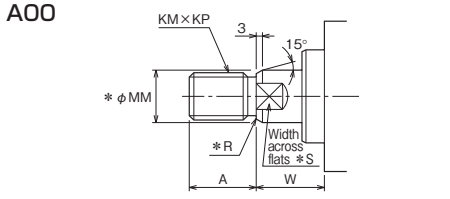

**A00** Table of Basic Dimensions (Standard dimensions)

Bore	A	KM	KP	*MM	*R	*S	W
φ32	25	M16	1.5	φ18	1	14	30
φ40	30	M20	1.5	φ22.4	1	19	30
φ50	35	M24	1.5	φ28	1	24	30
φ63	45	M30	1.5	φ35.5	1.6	30	35
φ80	60	M39	1.5	φ45	1.6	41	35
φ100	75	M48	1.5	φ56	1.6	50	40
φ125	95	M64	2	φ71	2	65	45
φ140	110	M72	2	φ80	2	75	50
φ150	115	M76	2	φ85	2	80	50
φ160	120	M80	2	φ90	2	85	55
φ180	140	M95	2	φ100	2		55
φ200	150	M100	2	φ112	2	Drill hole	55
φ224	180	M120	2	φ125	2		60
φ250	195	M130	2	φ140	2		65

Note) The number of chamfered surfaces DN is 2 (standard) or 4 only.

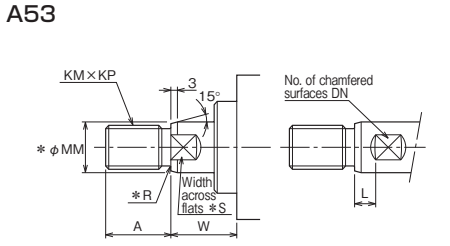

**A53** Table of Basic Dimensions

Bore	A	DN	KM	KP	L	*MM	*R	*S	W
φ32	25	2	M16	1.5	0	φ18	1	14	30
φ40	30	2	M20	1.5	0	φ22.4	1	19	30
φ50	35	2	M24	1.5	0	φ28	1	24	30
φ63	45	2	M30	1.5	0	φ35.5	1.6	30	35
φ80	60	2	M39	1.5	0	φ45	1.6	41	35
φ100	75	2	M48	1.5	0	φ56	1.6	50	40
φ125	95	2	M64	2	0	φ71	2	65	45
φ140	110	2	M72	2	0	φ80	2	75	50
φ150	115	2	M76	2	0	φ85	2	80	50
φ160	120	2	M80	2	0	φ90	2	85	55

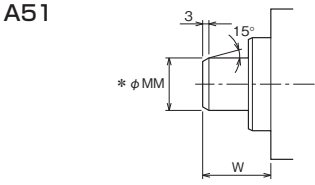

**A51** Table of Basic Dimensions

Bore	*MM	W
φ32	φ18	30
φ40	φ22.4	30
φ50	φ28	30
φ63	φ35.5	35
φ80	φ45	35
φ100	φ56	40
φ125	φ71	45
φ140	φ80	50
φ150	φ85	50
φ160	φ90	55
φ180	φ100	55
φ200	φ112	55
φ224	φ125	60
φ250	φ140	65

Use this shape to move the width across flats S of 'A00'.

- The \*-marked dimensions are fixed.
- If it is necessary to change the fixed dimensions, consult us.

### Rod B

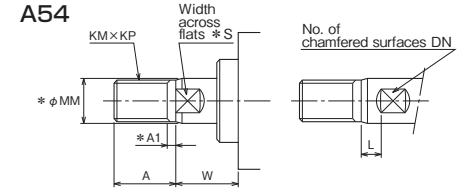

**A54** Table of Basic Dimensions

Bore	A	*A1	DN	KM	KP	L	*MM	*S	W
φ32	25	4	2	M16	1.5	0	φ18	14	30
φ40	30	4	2	M20	1.5	0	φ22.4	19	30
φ50	35	4	2	M24	1.5	0	φ28	24	30
φ63	45	4	2	M30	1.5	0	φ35.5	30	35
φ80	60	4	2	M39	1.5	0	φ45	41	35
φ100	75	4	2	M48	1.5	0	φ56	50	40
φ125	95	5	2	M64	2	0	φ71	65	45
φ140	110	5	2	M72	2	0	φ80	75	50
φ150	115	5	2	M76	2	0	φ85	80	50
φ160	120	5	2	M80	2	0	φ90	85	55
φ180	140	5		M95	2		φ100		55
φ200	150	5	Drill hole	M100	2	Drill hole	φ112	Drill hole	55
φ224	180	5		M120	2		φ125		60
φ250	195	5		M130	2		φ140		65

Note) The number of chamfered surfaces DN is 2 (standard) or 4 only.

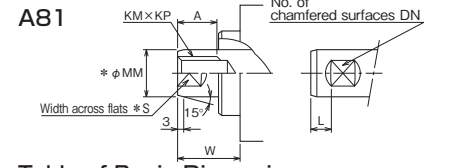

**A81** Table of Basic Dimensions

Bore	A	DN	KM	KP	L	*MM	*S	W
φ32	15	2	M12	1.75	0	φ18	14	30
φ40	20	2	M16	2	0	φ22.4	19	30
φ50	24	2	M20	2.5	0	φ28	24	30
φ63	33	2	M27	3	0	φ35.5	30	35
φ80	36	2	M30	3.5	0	φ45	41	35
φ100	45	2	M39	4	0	φ56	50	40
φ125	58	2	M48	2	0	φ71	65	45
φ140		2			0	φ80	75	50
φ150		2			0	φ85	80	50
φ160		2			0	φ90	85	55

For the cylinders with bores from 140 to 160 mm, basic dimensions have not been determined. When ordering them, specify the dimensions in the blank fields.

- The \*-marked dimensions are fixed.
- If it is necessary to change the fixed dimensions, consult us.

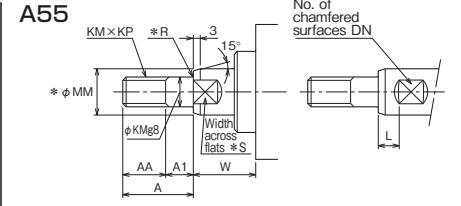

**A55** Table of Basic Dimensions

Bore	A	AA	A1	DN	KM	KP	L	*MM	*R	*S	W
φ50	44	30	14	2	M20	1.5	0	φ28	1.6	24	30
φ63	49	35	14	2	M24	1.5	0	φ35.5	2	30	35
φ80	59	45	14	2	M30	1.5	0	φ45	2	41	35
φ100	74	60	14	2	M39	1.5	0	φ56	2	50	40
φ125	89	75	14	2	M48	1.5	0	φ71	2.5	65	45
φ140	100	80	20	2	M56	2	0	φ80	2.5	75	50
φ150	105	85	20	2	M60	2	0	φ85	2.5	80	50
φ160	115	95	20	2	M64	2	0	φ90	2.5	85	55

For the cylinders with bores of 32 and 40 mm, basic dimensions have not been determined. Consult us when you request for them. When changing dimension A1, change it to 10 or more. Specify dimensions AA and A1 at the same time.

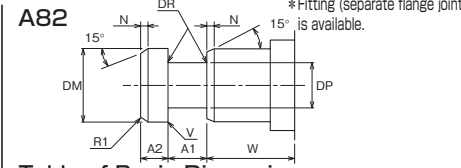

**A82** Table of Basic Dimensions

Bore	*A1 <sup>+0.05</sup> / <sub>+0.3</sub>	*A2 <sup>-0.2</sup> / <sub>-0.3</sub>	*DM	*DP <sup>-0.2</sup> / <sub>-0.3</sub>	*DR	*MM	*N	*V	W
φ32	12.5	12.5	φ18	φ13	1.0	φ18	3	C0.2	30
φ40	12.5	12.5	φ22.4	φ16	1.5	φ22.4	3	C0.2	30
φ50	12.5	12.5	φ28	φ21	1.5	φ28	3	C0.2	30
φ63	15	15	φ35.5	φ26	2.0	φ35.5	3	C0.2	35
φ80	15	15	φ45	φ31	2.0	φ45	3	C0.2	35
φ100	20	20	φ56	φ38	3.0	φ56	3	C0.2	40
φ125	25	25	φ71	φ49	3.5	φ71	3	R1	45
φ140	25	25	φ80	φ56	4.0	φ80	3	R1	50
φ150	30	30	φ85	φ58	5.0	φ85	6	R1	50
φ160	30	30	φ90	φ60	5.0	φ90	6	R1	55

MM is the rod diameter.

### Rod A Special Rod End Shapes

#### A00

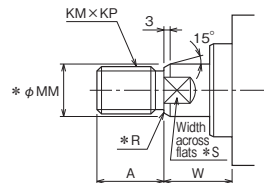

Table of Basic Dimensions (Standard dimensions)

Bore	A	KM	KP	*MM	*R	*S	W
φ40	35	M24	1.5	φ28	1	24	35
φ50	45	M30	1.5	φ35.5	1.6	30	41
φ63	60	M39	1.5	φ45	1.6	41	48
φ80	75	M48	1.5	φ56	1.6	50	51
φ100	95	M64	2	φ71	2	65	57
φ125	120	M80	2	φ90	2	85	57
φ140	140	M95	2	φ100	2	Drill hole	57
φ150	140	M95	2	φ100	2	Drill hole	57
φ160	150	M100	2	φ112	2	Drill hole	57

#### A51

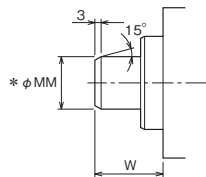

Table of Basic Dimensions

Bore	*MM	W
φ40	φ28	35
φ50	φ35.5	41
φ63	φ45	48
φ80	φ56	51
φ100	φ71	57
φ125	φ90	57
φ140	φ100	57
φ150	φ100	57
φ160	φ112	57

#### A53

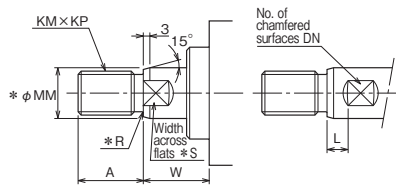

Table of Basic Dimensions

Bore	A	DN	KM	KP	L	*MM	*R	*S	W
φ40	35	2	M24	1.5	0	φ28	1	24	35
φ50	45	2	M30	1.5	0	φ35.5	1.6	30	41
φ63	60	2	M39	1.5	0	φ45	1.6	41	48
φ80	75	2	M48	1.5	0	φ56	1.6	50	51
φ100	95	2	M64	2	0	φ71	2	65	57
φ125	120	2	M80	2	0	φ90	2	85	57

Use this shape to move the width across flats S of 'A00'.

- The \*-marked dimensions are fixed.
- If it is necessary to change the fixed dimensions, consult us.

#### A54

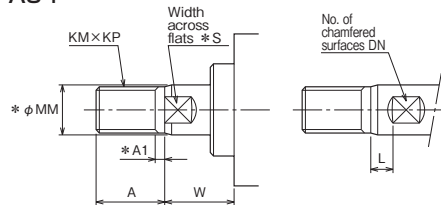

Table of Basic Dimensions

Bore	A	*A1	DN	KM	KP	L	*MM	*S	W
φ40	35	4	2	M24	1.5	0	φ28	24	35
φ50	45	4	2	M30	1.5	0	φ35.5	30	41
φ63	60	4	2	M39	1.5	0	φ45	41	48
φ80	75	4	2	M48	1.5	0	φ56	50	51
φ100	95	5	2	M64	2	0	φ71	65	57
φ125	120	5	2	M80	2	0	φ90	85	57
φ140	140	5	Drill hole	M95	2	Drill hole	φ100	Drill hole	57
φ150	140	5	↑	M95	2	↑	φ100	Drill hole	57
φ160	150	5	↑	M100	2	↑	φ112	Drill hole	57

### Rod A

#### A55

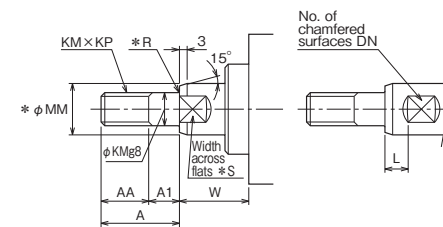

Table of Basic Dimensions

Bore	A	AA	A1	DN	KM	KP	L	*MM	*R	*S	W
φ40	44	30	14	2	M20	1.5	0	φ28	1.6	24	35
φ50	49	35	14	2	M24	1.5	0	φ35.5	2	30	41
φ63	59	45	14	2	M30	1.5	0	φ45	2	41	48
φ80	74	60	14	2	M39	1.5	0	φ56	2	50	51
φ100	89	75	14	2	M48	1.5	0	φ71	2.5	65	57
φ125	115	95	20	2	M64	2	0	φ90	2.5	85	57

When changing dimension A1, change it to 10 or more. Specify dimensions AA and A1 at the same time.

#### A81

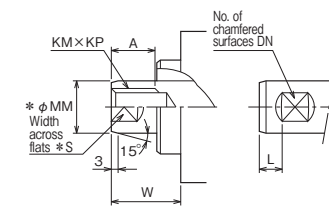
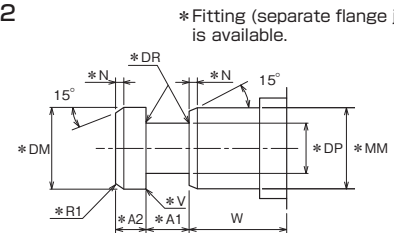

Table of Basic Dimensions

Bore	A	DN	KM	KP	L	*MM	*S	W
φ40	24	2	M20	2.5	0	φ28	24	35
φ50	33	2	M27	3	0	φ35.5	30	41
φ63	36	2	M30	3.5	0	φ45	41	48
φ80	45	2	M39	4	0	φ56	50	51
φ100	58	2	M48	2	0	φ71	65	57

Note) ● The number of chamfered surfaces DN is 2 (standard) or 4 only.

#### A82



\* Fitting (separate flange joint) is available.

Table of Basic Dimensions

Bore	*A1	*A2	*DM	*DP	*DR	*MM	*N	*V	W
φ40	12.5	12.5	φ28	φ21	1.5	φ28	3	C0.2	35
φ50	15	15	φ35.5	φ26	2.0	φ35.5	3	C0.2	41
φ63	15	15	φ45	φ31	2.0	φ45	3	C0.2	48
φ80	20	20	φ56	φ38	3.0	φ56	3	C0.2	51
φ100	25	25	φ71	φ49	3.5	φ71	3	R1	57
φ125	30	30	φ90	φ60	5.0	φ90	6	R1	57

MM is the rod diameter.

- The \*-marked dimensions are fixed.
- If it is necessary to change the fixed dimensions, consult us.

Separate Flange Joint (M-end): Only for piston rod end shape A82

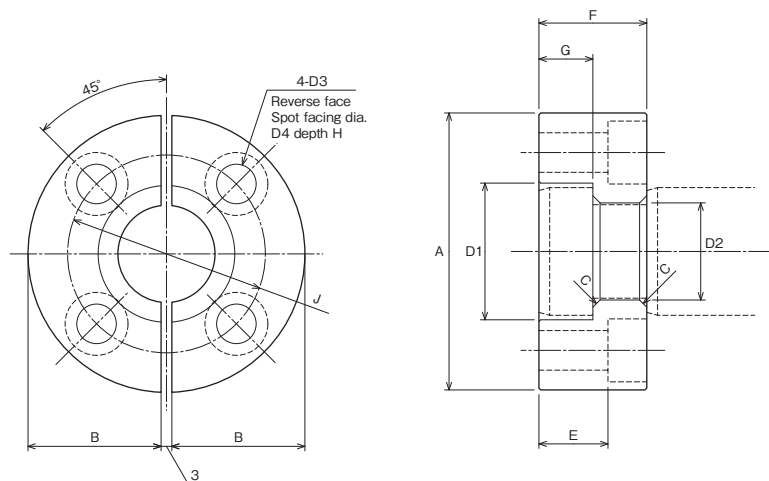

● Additional order for this item is needed. Specify as RMH- \* \* .

Dimensional Table/Rod B

Symbol Bore	Part number	A	B	C	D1	D2	D3	D4	E	F	G	H	J	X
φ32	RMH-18	φ49	23	1	φ19	φ13.5	φ6.6	φ11	18.5	25	12.5	6.5	φ34	-
φ40	RMH-22	φ57	27	1.5	φ23	φ16.5	φ9	φ14	16.4	25	12.5	8.6	φ40	-
φ50	RMH-28	φ71	34	1.5	φ29	φ21.5	φ11	φ17.5	14.2	25	12.5	10.8	φ50	-
φ63	RMH-36	φ77	37	2	φ38	φ27	φ11	φ17.5	19.2	30	15	10.8	φ55	-
φ80	RMH-45	φ100	48.5	2	φ48	φ33	φ14	φ20	17	30	15	13	φ76	16
φ100	RMH-56	φ124	60.5	3	φ60	φ41	φ18	φ26	22.5	40	20	17.5	φ92	7
φ125	RMH-70	φ150	73.5	3.5	φ74	φ53	φ22	φ32	28.5	50	25	21.5	φ112	14
φ140	RMH-80	φ174	85.5	4	φ84	φ60	φ26	φ39	24.5	50	25	25.5	φ129	40
φ150	RMH-85	φ180	88.5	5	φ90	φ62	φ26	φ39	34.5	60	30	25.5	φ135	26
φ160	RMH-90	φ193	95	5	φ95	φ64	φ30	φ43	31	60	30	29	φ144	9

Note) In the case of LC mounting and rod B, add dimension X as the lower limit to dimension W of the cylinder body.

Dimensional Table/Rod A

Symbol Bore	Part number	A	B	C	D1	D2	D3	D4	E	F	G	H	J	X
φ40	RMH-28	φ71	34	1.5	φ29	φ21.5	φ11	φ17.5	14.2	25	12.5	10.8	φ50	15
φ50	RMH-36	φ77	37	2	φ38	φ27	φ11	φ17.5	19.2	30	15	10.8	φ55	-
φ63	RMH-45	φ100	48.5	2	φ48	φ33	φ14	φ20	17	30	15	13	φ76	17
φ80	RMH-56	φ124	60.5	3	φ60	φ41	φ18	φ26	22.5	40	20	17.5	φ92	24
φ100	RMH-70	φ150	73.5	3.5	φ74	φ53	φ22	φ32	28.5	50	25	21.5	φ112	26
φ125	RMH-90	φ193	95	5	φ95	φ64	φ30	φ43	31	60	30	29	φ144	43

Note) In the case of LB mounting and rod A, add dimension Y as the lower limit to dimension W of the cylinder body.

## Setting method of sensor detection position

## AX type

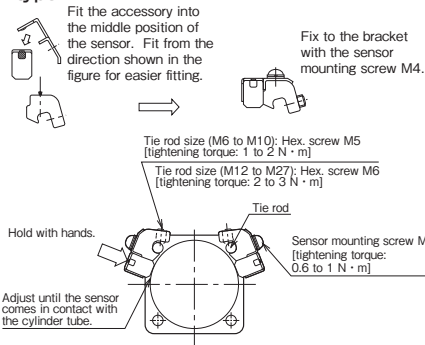

## WR type/WS type

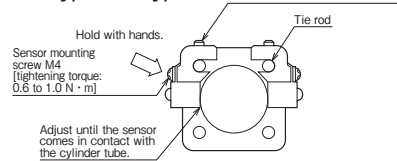

## Notes on assembly

## Tightening of tie rods

- DO NOT tighten only one tie rod at a time, but tighten them gradually in the order shown in the right diagram. Uneven tightening of the tie rods can cause operation failure or stick-slip.

1. Loosen the two hex. screws with a hex. wrench, and move them along the tie rod.
2. Adjust the detecting position (for the 2-LED type, the position where the green lamp lights up) 2 to 5 mm (about half of the operating range is appropriate) before the required position where the sensor indicator lamp starts to light up (ON). Then, gently hold the top of the sensor so that the cylinder tube contacts the detecting face of the sensor, and clamp the hex. screw to an appropriate tightening torque.  
Note) Inappropriate tightening torque may cause the off-center of the sensor position.
3. The indicating lamp lights up when the sensor is set to the ON position.  
(The lamp of SR405 goes out when sensor is turns on.)
4. Sensors can be mounted to any of four tie rods and on the most suitable position depending on the mounting space of the cylinder and wiring method.
5. Mount a sensor to the most suitable position to detect the stroke end with the "sensor mounting dimension" (dimension UX).

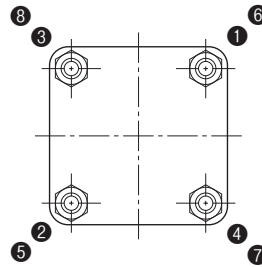

## Specified Tie Rod Tightening Torque Table

Bore (mm)	φ32	φ40	φ50	φ63	φ80	φ100	φ125	
Tie rod screw	M10×1.25	M10×1.25	M10×1.25	M12×1.5	M16×1.5	M18×1.5	M22×1.5	
Tightening torque (N·m)	70H-8	20	41	41	35	87	130	240
	140H-8	20	41	41	70	170	250	460

Bore (mm)	φ140	φ150	φ160	φ180	φ200	φ224	φ250	
Tie rod screw	M24×1.5	M27×1.5	M27×1.5	M30×1.5	M33×1.5	M39×1.5	M42×1.5	
Tightening torque (N·m)	70H-8	310	450	450	630	830	1400	1800
	140H-8	610	880	880	1100	1400	2400	3000

## Precautions for use

Since a cylinder with the rod A has a smaller pressure receiving area on the rod side, and the pressure in the cylinder can easily increase, take sufficient care to prevent the pressure from exceeding the maximum allowable pressure.

## &lt;Example&gt;

Find the pressure on the rod side when the cylinder is moved forward (lowered) under the following conditions.

Cylinder: 140H-8, φ80, rod A  
 Load: W = 1000 kg (≒ 10000 N)  
 Set pressure: P<sub>H</sub> = 8 MPa  
 Installation direction: Rod facing downward  
 Speed control: Meter-out  
 The operating speed is low, and the load rate is 100%.

## &lt;Answer&gt;

The pressure P<sub>R</sub> generated on the rod side is the sum of the pressure P<sub>1</sub> generated to balance with the load W and the pressure P<sub>2</sub> boosted up by the supply from the cap side.

- Pressure P<sub>1</sub> generated to balance with the load

$$P_1 = \frac{W}{A_R} = \frac{10000(\text{N})}{2564(\text{mm}^2)} = 3.9(\text{MPa})$$

- Pressure P<sub>2</sub> boosted up by the supply from the cap side  
Where, P<sub>2</sub>A<sub>R</sub> = P<sub>H</sub>A<sub>H</sub>

$$P_2 = \frac{P_H A_H}{A_R} = \frac{8(\text{MPa}) \times 5027(\text{mm}^2)}{2564(\text{mm}^2)} = 15.7(\text{MPa})$$

- The pressure P<sub>R</sub> generated on the rod side

$$P_R = P_1 + P_2 = 3.9 + 15.7 = 19.6(\text{MPa})$$

∴ The pressure exceeds the maximum allowable pressure on the rod side for the 140H-8 rod A type cylinder, 18 MPa, shown in the standard specifications, and, therefore, the cylinder is unusable. Recalculate after changing the conditions.

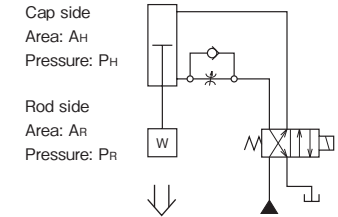

## Addition of new cylinders with stroke adjuster on retraction side to 70/140H-8 Series

- 32 to 160 mm bore hydraulic cylinders for 7/14 MPa with stroke adjuster on retraction side.
- Fine adjustments can be made to stroke by changing the depth of screwing of the stroke adjusting rod.
- The drop prevention mechanism has been adopted as a safety measure for the adjusting rod.
- Two kinds of stroke adjustment allowance, 5 mm and 10 mm, are available.
- After adjustment, the cushion stroke is identical to or more than that of the standard 70/140H-8 cylinders.
- The sensors, rod end attachments and boots are the same as those of 70/140H-8.

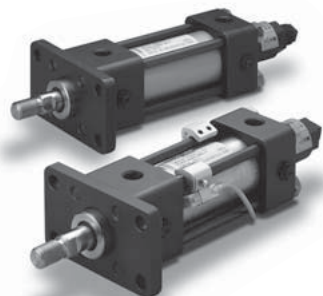

### Standard Specifications

Type	General purpose type	
	7 MPa	14 MPa
Nominal pressure	7 MPa	14 MPa
Maximum allowable pressure	Cap side : 9 MPa Rod side : (B) 13.5 MPa (C) 11 MPa	Cap side : 18 MPa Rod side : (B) 18 MPa (C) 14 MPa
	Proof test pressure	10.5 MPa
Minimum operating pressure	Cap side : 0.3 MPa or less	
	Rod side : (B) 0.45 MPa or less (C) 0.4 MPa or less	
Working speed range	$\phi 32$ to $\phi 63$ : 8 to 400mm/s $\phi 80$ to $\phi 125$ : 8 to 300mm/s $\phi 140$ to $\phi 160$ : 8 to 200mm/s	
Working temperature range (ambient temperature)	Standard type ..... -10 to +80°C	
	Switch Set AX type ..... -10 to +70°C	
Structure of cushioning	WR/WS type ..... -10 to +60°C (No freezing)	
	Metal fitting system	
Adaptable fluid	Petroleum-based fluid	
	(When using another fluid, refer to the table of fluid adaptability.)	
Tolerance for thread	JIS 6g/6H	
Tolerance of stroke	0 to 100 mm $^{+0.8}_0$ 101 to 250 mm $^{+1.0}_0$ 251 to 630 mm $^{+1.25}_0$	
	631 to 1000 mm $^{+1.4}_0$ 1001 to 1600 mm $^{+1.6}_0$ 1601 to 2000 mm $^{+1.8}_0$	
Mounting style	SD · LA · LB · FA · FC ·	SD · LA · FC ·
	FK · FY · TA · TC	FK · TA · TC
Accessories	• Rod eye (T-end), rod eye with spherical bearing (S-end)	
	• Rod clevis (Y-end) with pin, lock nut	
	• Floating joint (F-end): Only for 7-MPa type	
	• Boots: Standard: Nylon tarpaulin Semi-standard: Chloroprene, Conex	

### Terminologies

#### Nominal pressure

Pressure given to a cylinder for convenience of naming. It is not always the same as the working pressure (rated pressure) that guarantees performance under the specified conditions.

#### Maximum allowable pressure

The maximum allowable pressure generated in a cylinder (surge pressure, etc.)

#### Proof test pressure

Test pressure against which a cylinder can withstand without unreliable performance at the return to nominal pressure.

#### Minimum operating pressure

The minimum pressure that a cylinder placed horizontally without a load can work.

#### Notes

- The hydraulic pressure generated in a cylinder due to the inertia of load must be lower than the maximum allowable pressure.
- The working temperature range depends on the seal material. For details, refer to the selection materials at the beginning of this catalog.
- The standard type cylinders can be used up to the working temperature range shown in the selection materials by using seal material ⑥, HNBR.
- In case that the lock nut is attached to the piston rod end thread part, increase the thread length (dimension A).
- Conex, material of the boots, is the registered trademark of Teijin Limited.

### Product Lineup

Unit: mm

Series Variations	Type	Rod dia.	$\phi 32$	$\phi 40$	$\phi 50$	$\phi 63$	$\phi 80$	$\phi 100$	$\phi 125$	$\phi 140$	$\phi 150$	$\phi 160$
General purpose type	Double acting single rod	Standard type 70/140H-8A2	Rod B	●	●	●	●	●	●	●	●	●
			Rod C	●	●	●	●	●	●	●	●	●
	Switch Set 70/140H-8A2	Rod B	●	●	●	●	●	●	●	●	●	●
		Rod C	●	●	●	●	●	●	●	●	●	●

- Notes) • When using a sensor, use a Switch Set Cylinder.  
• No sensor can be mounted onto the standard type cylinder.

### Cushion Stroke on Rod Side

Bore	Cushion ring length L	Cushion ring parallel part length $l$
$\phi 32$	25	7
$\phi 40$ to $\phi 63$	25	7
$\phi 80$ to $\phi 125$	25	8
$\phi 140$ to $\phi 160$	30	12

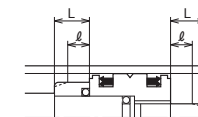

### Cushion Stroke on Cap Side

Bore	Adjustment allowance of 5 mm		Adjustment allowance of 10 mm	
	Cushion ring length L	Cushion ring parallel part length $l$	Cushion ring length L	Cushion ring parallel part length $l$
$\phi 32$	28	12	33	17
$\phi 40$ to $\phi 63$	30	12	35	17
$\phi 80$ to $\phi 125$	30	13	35	18
$\phi 140$ to $\phi 160$	35	17	40	22

Note) These cushion strokes on the cap side are obtained when the stroke adjustment amount is 0 mm. The cushion strokes will be reduced by the actual stroke adjustment allowance.

### Image of Adjustment Structure

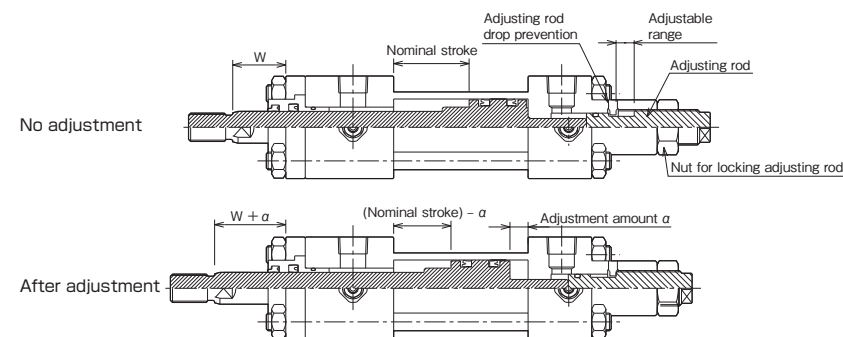

### How to order

#### General Purpose Type

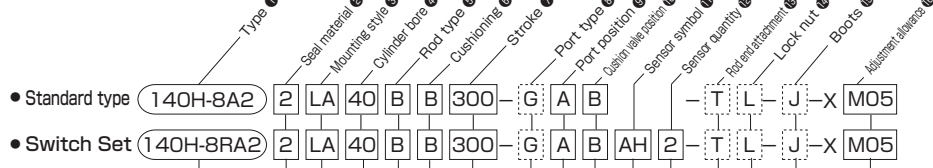

Double acting single rod

- For 7 MPa  
70H-8A2 : Standard type  
70H-8RA2 : Switch Set
- For 14 MPa  
140H-8A2 : Standard type  
140H-8RA2 : Switch Set

- 1 Nitrile rubber ( $\phi 32$  to  $\phi 160$ )
- 2 Urethane rubber ( $\phi 32$  to  $\phi 160$ )
- 3 Fluorocarbon ( $\phi 32$  to  $\phi 160$ )
- 6 HNBR ( $\phi 32$  to  $\phi 160$ )
- 8 Slipper seal ( $\phi 32$  to  $\phi 100$ )

Notes) The material of Slipper seal is nitrile rubber except for the piston. Switch Set Cylinders are not provided with Slipper seals.

Mounting style

Standard type :  $\phi 32$  to  $\phi 160$   
Switch Set :  $\phi 32$  to  $\phi 140$

Note) Rod C is applicable to cylinders with a bore of 40 mm or more.

- B Rod B
- C Rod C

- B With cushions on both ends
- R With cushion on the rod side
- H With cushion on the cap side
- N No cushion

Cylinder stroke (mm)

- M05 Adjustment allowance: 5 mm
- M10 Adjustment allowance: 10 mm
- J Nylon tarpaulin
- JN Chloroprene
- JK Conex
- L With lock nut

- T Rod eye (T-end)
- S Rod eye with spherical bearing (S-end)
- Y Rod clevis (Y-end)
- F Floating joint (F-end) (for 7 MPa)

Sensor quantity (1, 2, to n)  
Sensor symbol  
Note) Select applicable sensors out of the Sensor List.

- Notes on ordering Switch Set
  - When no sensor is required, specify 0 for the sensor symbol and the sensor quantity.
  - Sensors are not mounted on cylinders at delivery.

Cushion valve position (A, B, C, D, O)

- Port position (A, B, C, D)
- None Rc thread
  - G G thread (Order made)
  - N NPT thread (Order made)

#### Mounting style

- SD SD style (basic style)
- LA LA style (side lugs)
- LB LB style (end angles) (for 7 MPa)
- FA FA style (rod rectangular flange) (for 7 MPa)
- FY FY style (cap rectangular flange) (for 14 MPa)



- FC FC style (rod square flange)
- FK FK style (intermediate side lugs)
- TA TA style (rod trunnion)
- TC TC style (intermediate trunnion)

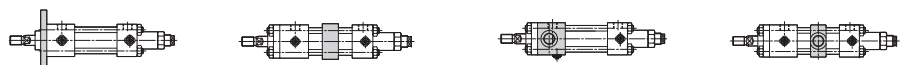

### Sensor List

Type	Sensor symbol	Load voltage range	Load current range	Max. switching capacity	Protective circuit	Indicating lamp	Wiring method	Cord length	Applicable load
Reed sensor	AF AX101CE				None	LED (Lights in red when sensing)	0.3 mm <sup>2</sup> , 2-core, outer dia. $\phi$ 4 mm Rear wiring	1.5m	Small relay, programmable controller
	AG AX105CE	DC:5 to 30V	DC:5 to 40mA	DC:1.5W	Provided	LED (Lights in red when sensing)	0.3 mm <sup>2</sup> , 2-core, outer dia. $\phi$ 4 mm Rear wiring	5m	
	AH AX111CE	AC:5 to 120V	AC:5 to 20mA	AC:2VA				1.5m	
	AJ AX115CE				None	None	0.3 mm <sup>2</sup> , 2-core, outer dia. $\phi$ 4 mm Rear wiring	5m	
	AE AX125CE	DC:30 V or less AC:120 V or less	DC:40 mA or less AC:20 mA or less					5m	
	AK AX11ACE	AC:5 to 120V	5 to 20mA	2VA	Provided	LED (Lights in red when sensing)	4-pin connector type, Rear wiring	0.5m	
	AL AX11BCE	DC:5 to 30V	5 to 40mA	1.5W	None	LED (Lights in red when sensing)	0.3 mm <sup>2</sup> , 2-core, outer dia. $\phi$ 4 mm Upper wiring	0.5m	
	AP AZ101CE							1.5m	
	AR AZ105CE	DC:5 to 30V	DC:5 to 40mA	DC:1.5W	Provided	LED (Lights in red when sensing)	0.3 mm <sup>2</sup> , 2-core, outer dia. $\phi$ 4 mm Upper wiring	5m	
	AS AZ111CE	AC:5 to 120V	AC:5 to 20mA	AC:2VA				1.5m	
	AT AZ115CE				None	None	0.3 mm <sup>2</sup> , 2-core, outer dia. $\phi$ 4 mm Upper wiring	5m	
	AN AZ125CE	DC:30 V or less AC:120 V or less	DC:40 mA or less AC:20 mA or less					5m	
	AU AZ11ACE	AC:5 to 120V	5 to 20mA	2VA	Provided	LED (Lights in red when sensing)	4-pin connector type, Upper wiring	0.5m	
	AW AZ11BCE	DC:5 to 30V	5 to 40mA	1.5W	None	LED (Lights in red when sensing)	0.3 mm <sup>2</sup> , 2-core, outer dia. $\phi$ 4 mm Rear wiring	0.5m	
	5 WR505	DC:5 to 50V	DC:3 to 40mA	DC:1.5W				5m	
7 WR505F	AC:5 to 120V	AC:3 to 20mA	AC:2VA	None	LED (Lights in red when sensing)	0.3 mm <sup>2</sup> , 2-core, outer dia. $\phi$ 4 mm Rear wiring	5m		
6 WR515							5m		
AM AX135CE	AC/DC:90 to 240V	5 to 300mA	B contact output	Provided	LED (Lights in red when not sensing)	0.3 mm <sup>2</sup> , 2-core, outer dia. $\phi$ 4 mm Upper wiring	5m		
AY AZ135CE				Provided	Neon lamp (Lights when not sensing)	0.5 mm <sup>2</sup> , 2-core, outer dia. $\phi$ 6 mm, Rear wiring	5m		
S SR405	AC:80 to 220V	2 to 300mA	30VA				5m		
Solid state sensor	BE AX201CE-1	DC:5 to 30V	5 to 40mA	—	Provided	LED (Lights in red when sensing)	0.3 mm <sup>2</sup> , 2-core, outer dia. $\phi$ 4 mm Rear wiring	1.5m	Small relay, programmable controller
	BF AX205CE-1					LED (2-LED type in red/green)	0.3 mm <sup>2</sup> , 2-core, outer dia. $\phi$ 4 mm Rear wiring	5m	
	CE AX211CE-1					LED (2-LED type in red/green)	4-pin connector type, Rear wiring	1.5m	
	CF AX215CE-1					LED (Lights in red when sensing)	0.3 mm <sup>2</sup> , 2-core, outer dia. $\phi$ 4 mm Upper wiring	5m	
	CH AX21CCE-1					LED (2-LED type in red/green)	0.3 mm <sup>2</sup> , 2-core, outer dia. $\phi$ 4 mm Upper wiring	1.5m	
	CJ AX21DCE-1					LED (2-LED type in red/green)	0.3 mm <sup>2</sup> , 2-core, outer dia. $\phi$ 4 mm Upper wiring	5m	
	BM AZ201CE-1					LED (Lights in red when sensing)	0.3 mm <sup>2</sup> , 2-core, outer dia. $\phi$ 4 mm Upper wiring	5m	
	BN AZ205CE-1					LED (2-LED type in red/green)	0.3 mm <sup>2</sup> , 2-core, outer dia. $\phi$ 4 mm Upper wiring	1.5m	
CM AZ211CE-1	LED (2-LED type in red/green)	0.3 mm <sup>2</sup> , 2-core, outer dia. $\phi$ 4 mm Upper wiring	5m						
CN AZ215CE-1									
Cutting oil proof type	RA AX205WCE	DC:10 to 30V	5 to 40mA	—	Provided	LED (Lights in red when sensing)	0.3 mm <sup>2</sup> , 2-core, outer dia. $\phi$ 4 mm, Rear wiring	5m	Small relay, programmable controller
	RB AZ205WCE		5 to 20mA			LED (2-LED type in red/green)	0.3 mm <sup>2</sup> , 2-core, outer dia. $\phi$ 4 mm, Upper wiring	5m	
	RE AX215WCE		5 to 20mA			LED (2-LED type in red/green)	0.3 mm <sup>2</sup> , 2-core, outer dia. $\phi$ 4 mm, Rear wiring	5m	
	RF AZ215WCE		5 to 20mA			LED (2-LED type in red/green)	0.3 mm <sup>2</sup> , 2-core, outer dia. $\phi$ 4 mm, Upper wiring	5m	
Solid state sensor (conforming to CE)	2 WS215-1	DC:10 to 30V	6 to 20mA	—	Provided	LED (2-LED type in red/green)	0.3 mm <sup>2</sup> , 2-core, outer dia. $\phi$ 4 mm Rear wiring	5m	Small relay, programmable controller
	4 WS215-1F					LED (2-LED type in red/green)	0.3 mm <sup>2</sup> , 2-core, outer dia. $\phi$ 4 mm Rear wiring	5m	
	3 WS225-1					LED (2-LED type in red/green)	0.3 mm <sup>2</sup> , 2-core, outer dia. $\phi$ 4 mm Rear wiring	5m	
Solid state sensor (conforming to CE)	CT AX211CE-1	DC:5 to 30V	5 to 40mA	—	Provided	LED (2-LED type in red/green)	0.3 mm <sup>2</sup> , 2-core, outer dia. $\phi$ 4 mm Rear wiring	1.5m	Small relay, programmable controller
	CU AX215CE-1						4-pin connector type, Rear wiring	5m	
	CV AX21BCE-1						4-pin connector type, Rear wiring	0.5m	
	CW AZ211CE-1						0.3 mm <sup>2</sup> , 2-core, outer dia. $\phi$ 4 mm Upper wiring	1.5m	
	CX AZ215CE-1						0.3 mm <sup>2</sup> , 2-core, outer dia. $\phi$ 4 mm Upper wiring	5m	
	CY AZ21BCE-1						4-pin connector type, Upper wiring	0.5m	
							4-pin connector type, Upper wiring	0.5m	

- Notes) ● For the sensors without a protective circuit, be sure to provide a protective circuit (SK-100) with the load when using any induction load (relay, etc.).  
 ● The output logic of AX and AZ135CE is B contact. When the piston is detected, the sensor contact turns off (the lamp turns on).  
 ● For the details of sensors, be sure to read the sensor specifications at the end of this catalog.  
 ● WR and WS type sensors are cutting oil proof. (Bores from 32 mm to 125 mm)  
 ● Sensor SR405 can be mounted only to cylinders with bores from 32 mm to 125 mm.  
 ● We recommend AND Unit (AU series) for multiple sensors connected in series.  
 For details, refer to AND Unit at the end of this catalog.

- Standard type  
AX type (Rear wiring)      AZ type (Upper wiring)
- Cutting oil proof type  
WR/WS type sensor
- When ordering the cutting oil proof type sensors, WR and WS types, please be carefully the following notification.



- 5 WR505 The sensor and straight box connector (F-SB) are combined (the flexible tube (F-0.5: 4.8 m) is required).
- 2 WS215-1 The flexible tube (F-0.5: 4.8 m) is attached to the required sensor and straight box connector (F-SB).
- 7 WR505F The flexible tube (F-0.5: 4.8 m) is attached to the required sensor and straight box connector (F-SB).
- 4 WS215-1F The flexible tube (F-0.5: 4.8 m) is attached to the required sensor and straight box connector (F-SB).

Standard Stroke Range

Bore	Standard type	Switch Set
φ32 to φ50	1200	1200
φ63 · φ80	1600	1600
φ100 to φ140	2000	2000
φ150 · φ160	2000	—

• The above strokes indicate the maximum available strokes for the standard type. For the rod buckling, check with the buckling chart in the selection materials. Contact us for longer strokes.

Adaptability of Fluid to Seal Material

Seal material	Adaptable fluid				
	Petroleum-based fluid	Water-glycol fluid	Phosphate ester fluid	Water in oil fluid	Water in oil fluid
① Nitrile rubber	○	○	×	○	○
② Urethane rubber	◎	×	×	△	△
③ Fluorocarbon	○	×	○	○	○
⑥ HNBR	○	◎	×	◎	◎

Notes) 1. ◎○: Applicable ×: Inapplicable  
 Consult us before using the △-marked items.  
 2. The ◎-marked items are recommended seal materials in case of giving the first priority to abrasion resistance.

Cutting Oil Proof Type: Adaptability of cutting oil to seal material

Seal material	Nonaqueous cutting oil		Aqueous cutting oil
	Type 1	Type 2	
⑥ HNBR	○	×	○

Note) ○: Applicable ×: Inapplicable

For the working temperature range of seal materials, refer to the selection materials at the beginning of this catalog.

Standard specifications

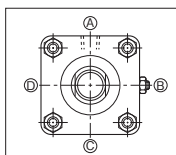

- With cushions on both ends
- Port position ①, cushion valve position ②

Change of port and cushion valve positions

The standard port position is ①, and the standard cushion valve position is ②. When modifying the positions, enter the symbol shown in the dimensional drawings.

Example)  
 70H-8A2 2SD80BB100—B C AH2-XM05

Port position (A, B, C, D)

Cushion valve position (A, B, C, D, O)

- For the TA style, the standard port position and cushion valve position are ① and ② on the rod side and ③ and ④ on the cap side.
- In case that the cushion is not equipped, the cushion valve position is "O".

Delivery of rod end attachment (T-end or Y-end)

A delivery method for a cylinder provided with a lock nut and a rod end attachment differs from that for a cylinder provided with a rod end attachment only (without a lock nut). For details, refer to the dimensional drawings of rod end attachments for 70/140H-8 Series.

Thread Dimension Table

Unit: mm

Bore	G thread			NPT thread
	AE	DE	FF	
φ32	12	φ25.5	G3/8	NPT3/8
φ40	12	φ25.5	G3/8	NPT3/8
φ50	14	φ30	G1/2	NPT1/2
φ63	14	φ30	G1/2	NPT1/2
φ80	16	φ36.9	G3/4	NPT3/4
φ100	16	φ36.9	G3/4	NPT3/4
φ125	18	φ46.1	G1	NPT1
φ140	18	φ46.1	G1	NPT1
φ150	18	φ46.1	G1	NPT1
φ160	18	φ46.1	G1	NPT1

Port G thread type (conforming to ISO1179-1) and NPT thread type (Order made)

For a port G thread type cylinder, make an order in accordance with the following procedure.

(Example)

70H-8A2 2LA50BB100—G A B—XM05

G : Port G thread type

N : NPT thread type

Port position

Cushion valve position

Port G thread type

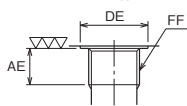

Sensor Mountable Minimum Stroke

Unit: mm

Bore mm	Mounting style	Styles other than TC						TC style					
		With one sensor			With two sensors			With one sensor			With two sensors		
		AX type	WR type	WS type	AX type	WR type	WS type	AX type	WR type	WS type	AX type	WR type	WS type
φ32	20	45 (35)	25	45 (35)	50	70 (60) / 75 (65)	110	155 (135) / 165 (145)	165 (145)				
φ40	20	45 (35)	25	45 (35)	50	70 (60) / 75 (65)	115	155 (135) / 165 (145)	165 (145)				
φ50	20	40 (30) / 45 (35)	25	40 (30) / 45 (35)	50	70 (60) / 75 (65)	115	155 (135) / 165 (145)	165 (145)				
φ63	20	40 (30)	25	40 (30)	60	85 (75)	125	170 (150) / 175 (155)	175 (155)				
φ80	20	40 (30)	25	40 (30)	60	85 (75)	130	170 (150) / 175 (155)	175 (155)				
φ100	20	35 (25) / 40 (30)	25	35 (25) / 40 (30)	65	85 (75) / 95 (85)	135	175 (150) / 190 (170)	190 (170)				
φ125	20	35 (25) / 40 (25)	25	35 (25) / 40 (25)	70	90 (80) / 95 (85)	150	185 (160) / 195 (170)	195 (170)				
φ140	20	—	—	25	—	—	95	—	—	175	—	—	

Notes)

- For the TC style with one sensor, the cylinder strokes when the TC accessory is positioned at the place other than the center (as shown in the right figures) are shown in the table.
- For the minimum dimension PH of TC style for mounting sensor, refer to the dimensional drawings of TC style.
- The parenthesized values in the WR and WS type columns are the minimum strokes in case of WR515 or WS225.

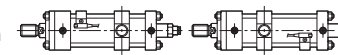

Weight Table

Unit: kg

Bore (mm)	Rod dia.	Basic weight (SD style)	Additional weight per mm of stroke	Mounting accessory weight								Rod end attachment weight					Sensor additional weight		
				LA	LB	FA	FC	FK	FY	TA	TC	Rod eye (T-end)	Rod eye (S-end)	Rod clevis (Y-end)	Floating joint (F-end)	Lock nut			
φ32	B	3.5	0.006	0.3	0.3	0.1	0.6	1.1	0.2	0.1	0.5	0.5	—	0.7	—	0.02	AX type		
φ40	B	3.8	0.011	0.5	0.5	0.2	0.7	1.2	0.3	0.1	0.6	0.5	0.7	0.7	0.39	0.03	(Cord length 1.5 m)		
	C	3.7	0.010														0.75	0.02	φ32 to φ50: 0.05
φ50	B	5.4	0.014	0.9	0.7	0.7	1.5	2.2	1.1	0.4	1.0	1.0	1.1	1.2	1.2	1.41	0.03	φ63 to φ100: 0.07	
	C	5.3	0.012															1.41	0.03
φ63	B	8.6	0.019	1.0	1.2	1.0	2.2	3.6	1.6	0.6	1.2	2.7	2.1	2.3	3.9	0.75	0.11	(Cord length 5 m)	
	C	8.3	0.017															2.68	0.05
φ80	B	17.1	0.032	1.8	2.0	1.1	2.8	4.7	2.1	0.6	2.1	2.2	3.2	3.6	3.7	1.41	0.24	φ63: 0.14	
	C	16.4	0.027															2.68	0.11
φ100	B	30.3	0.048	2.1	2.9	1.8	4.6	8.9	3.9	1.0	3.8	4.2	6.7	7.7	—	0.52	0.24	φ125-φ140: 0.16	
	C	29.2	0.042															0.24	(Connector type)
φ125	B	50.2	0.077	3.2	5.5	2.9	8.0	12.6	6.2	2.1	6.2	8.0	12.4	13.7	14.6	—	1.10	0.52	φ32 to φ50: 0.04
	C	49.8	0.065																0.52
φ140	B	69.6	0.100	3.8	7.7	3.2	9.2	20.4	8.2	4.1	11.1	19.0	—	28.8	—	1.44	0.77	φ125: 0.07	
	C	66.0	0.085															0.77	φ140: 0.08
φ150	B	81.2	0.118	4.8	9.6	4.9	16.6	22.9	10.7	4.6	10.9	18.9	—	28.3	—	1.65	—	SR type	
	C	79.5	0.101															0.94	φ32 to φ140: 0.22
φ160	B	99.0	0.121	5.4	10.0	5.3	19.0	31.2	11.3	5.2	14.8	22.7	—	34.2	—	1.93	—	WR/WS type	
	C	94.6	0.102															1.10	φ32 to φ140: 0.5

Calculation formula) Cylinder weight (kg)=basic weight+(cylinder stroke (mm)×additional weight per mm of stroke) + (sensor additional weight×sensor quantity)+mounting accessory weight+rod end attachment weight

Calculation example) 70H-8A2, bore φ50, rod B, cylinder stroke 200 mm, 2 pcs of AX215, LA style  
 5.4+ (200×0.014) + (0.13×2) +0.9=9.36kg

SD

70H-8A2	1	SD	Bore	B	B	Stroke	-	A	B	-	X	M05
140H-8A2	1	SD	Bore	B	B	Stroke	-	A	B	-	X	M05

- $\phi 32$  to  $\phi 80$

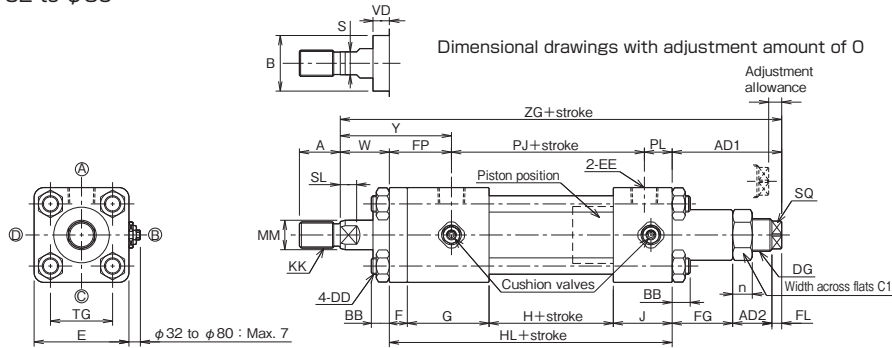

- $\phi 100$  to  $\phi 160$

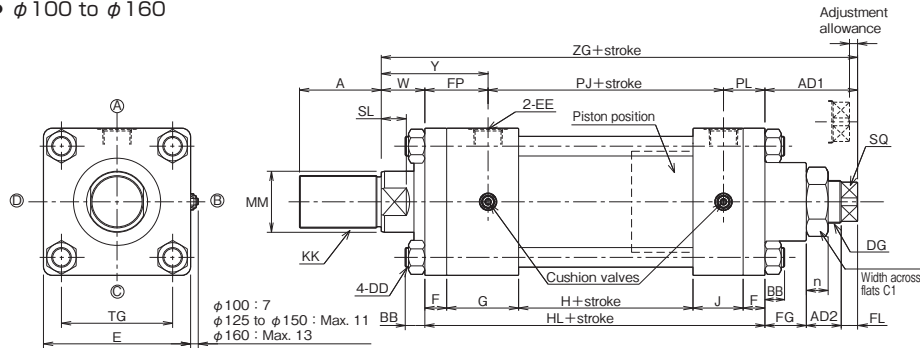

- For the dimensions of the sensors, refer to the catalog of 70/140H-8 Series.

Dimensional Table

Bore	Rod B							Rod C							BB	DD	E	EE	F
	A	B	KK	MM	S	SL	VD	A	B	KK	MM	S	SL	VD					
$\phi 32$	25	$\phi 34$	M16×1.5	$\phi 18$	14	10	10	—	—	—	—	—	—	—	11	M10×1.25	$\square 58$	Rc3/8	11
$\phi 40$	30	$\phi 40$	M20×1.5	$\phi 22.4$	19	11	10	25	$\phi 36$	M16×1.5	$\phi 18$	14	10	10	11	M10×1.25	$\square 65$	Rc3/8	11
$\phi 50$	35	$\phi 46$	M24×1.5	$\phi 28$	24	14	10	30	$\phi 40$	M20×1.5	$\phi 22.4$	19	11	10	11	M10×1.25	$\square 76$	Rc1/2	13
$\phi 63$	45	$\phi 55$	M30×1.5	$\phi 35.5$	30	16	10	35	$\phi 46$	M24×1.5	$\phi 28$	24	14	10	13	M12×1.5	$\square 90$	Rc1/2	15
$\phi 80$	60	$\phi 65$	M39×1.5	$\phi 45$	41	20	10	45	$\phi 55$	M30×1.5	$\phi 35.5$	30	16	9	16	M16×1.5	$\square 110$	Rc3/4	18
$\phi 100$	75	$\phi 80$	M48×1.5	$\phi 56$	50	23	10	60	$\phi 65$	M39×1.5	$\phi 45$	41	20	10	18	M18×1.5	$\square 135$	Rc3/4	20
$\phi 125$	95	$\phi 95$	M64×2	$\phi 71$	65	27	10	75	$\phi 80$	M48×1.5	$\phi 56$	50	23	10	21	M22×1.5	$\square 165$	Rc1	24
$\phi 140$	110	$\phi 105$	M72×2	$\phi 80$	75	31	10	80	$\phi 85$	M56×2	$\phi 63$	55	24	10	22	M24×1.5	$\square 185$	Rc1	26
$\phi 150$	115	$\phi 110$	M76×2	$\phi 85$	80	33	10	85	$\phi 90$	M60×2	$\phi 67$	60	30	10	25	M27×1.5	$\square 196$	Rc1	28
$\phi 160$	120	$\phi 115$	M80×2	$\phi 90$	85	33	10	95	$\phi 95$	M64×2	$\phi 71$	65	27	10	25	M27×1.5	$\square 210$	Rc1	31

Bore	FP	G	H	HL	J	PJ	PL	TG	W	Y	Adjustment allowance 5 mm			Adjustment allowance 10 mm			C1	DG	FG	FL	n	SQ
											AD1	AD2	ZG	AD1	AD2	ZG						
$\phi 32$	38	50	44	141	36	86	17	$\square 38$	30	68	62	19	233	67	24	238	27	M20×1.5	37	6	12	$\square 13$
$\phi 40$	38	50	44	141	36	88	15	$\square 45$	30	68	64	19	235	69	24	240	27	M20×1.5	39	6	12	$\square 13$
$\phi 50$	42	54	48	155	40	93	20	$\square 52$	30	72	60	19	245	65	24	250	27	M20×1.5	35	6	12	$\square 13$
$\phi 63$	46	56	52	163	40	102	15	$\square 63$	35	81	77	21	275	82	26	280	32	M24×1.5	50	6	14	$\square 17$
$\phi 80$	56	66	54	184	46	110	18	$\square 80$	35	91	81	24	300	86	29	305	41	M30×1.5	51	6	17	$\square 22$
$\phi 100$	58	66	60	212	46	116	38	$\square 102$	40	98	80	27	332	85	32	337	55	M39×1.5	38	15	20	$\square 30$
$\phi 125$	67	76	64	244	56	130	47	$\square 122$	45	112	81	33	370	86	38	375	70	M48×1.5	33	15	26	$\square 36$
$\phi 140$	69	76	72	256	56	138	49	$\square 138$	50	119	87	37	393	92	42	398	80	M56×2	35	15	30	$\square 41$
$\phi 150$	71	76	80	268	56	146	51	$\square 148$	50	121	93	40	411	98	45	416	85	M60×2	38	15	33	$\square 46$
$\phi 160$	74	81	80	284	61	156	54	$\square 160$	55	129	96	42	435	101	47	440	90	M64×2	39	15	35	$\square 50$